

FENCE TYPE HAY SELF FEEDER

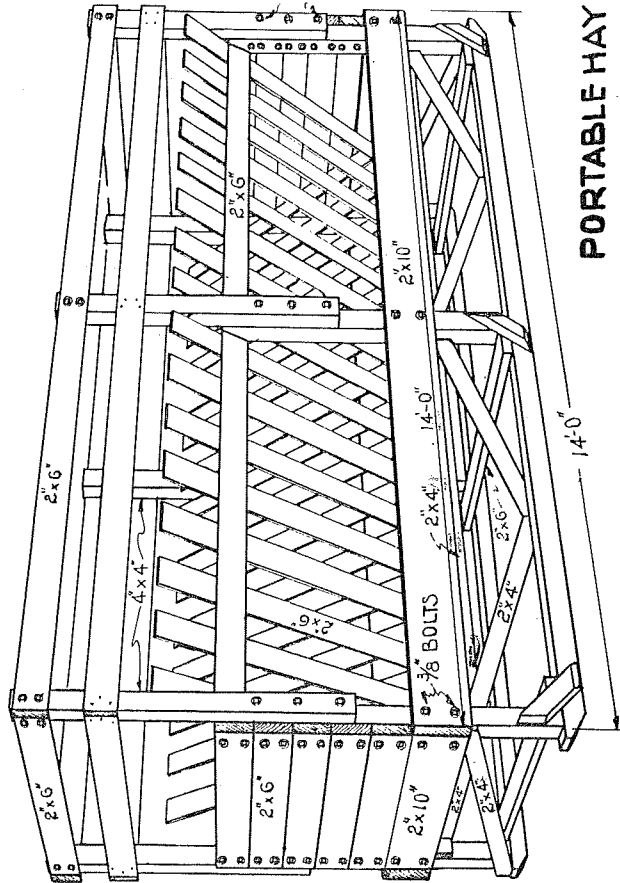

PORTABLE HAY FEEDER

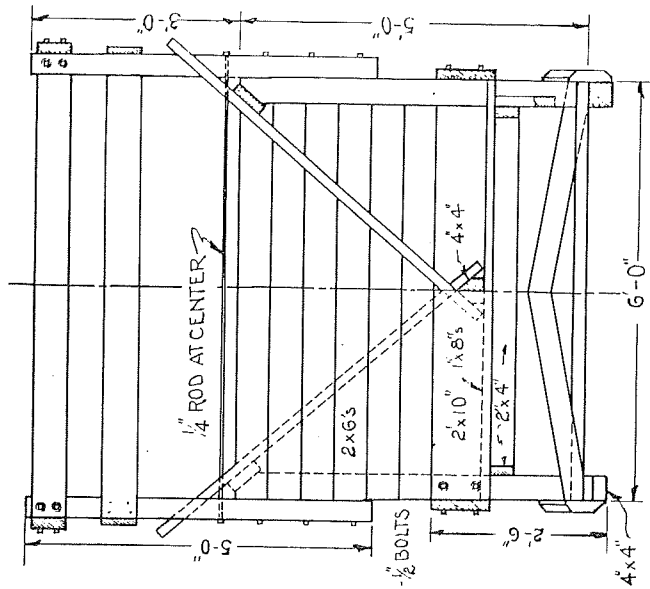
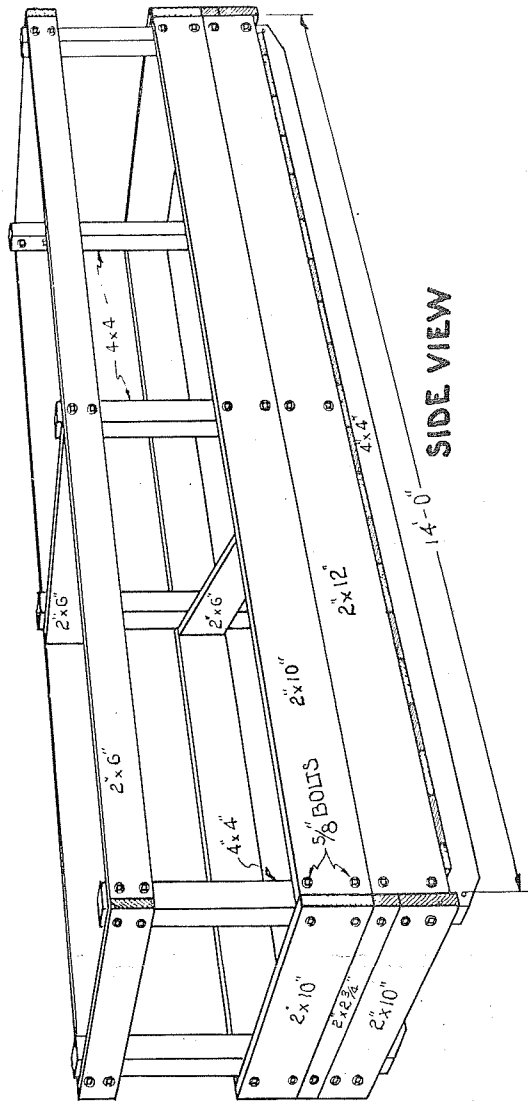

SIDE VIEW

SECTION

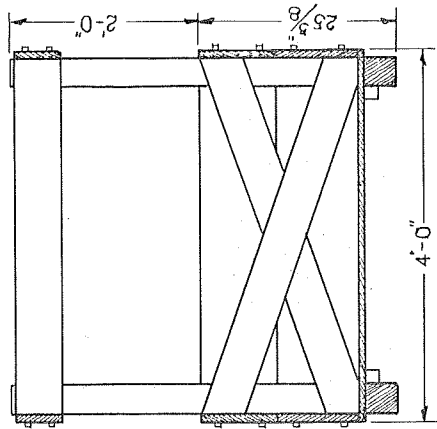

NOTE
SEE INSIDE PAGE FOR
BILLS OF MATERIAL

PORTABLE HAY-GRAIN OR SILAGE FEEDER

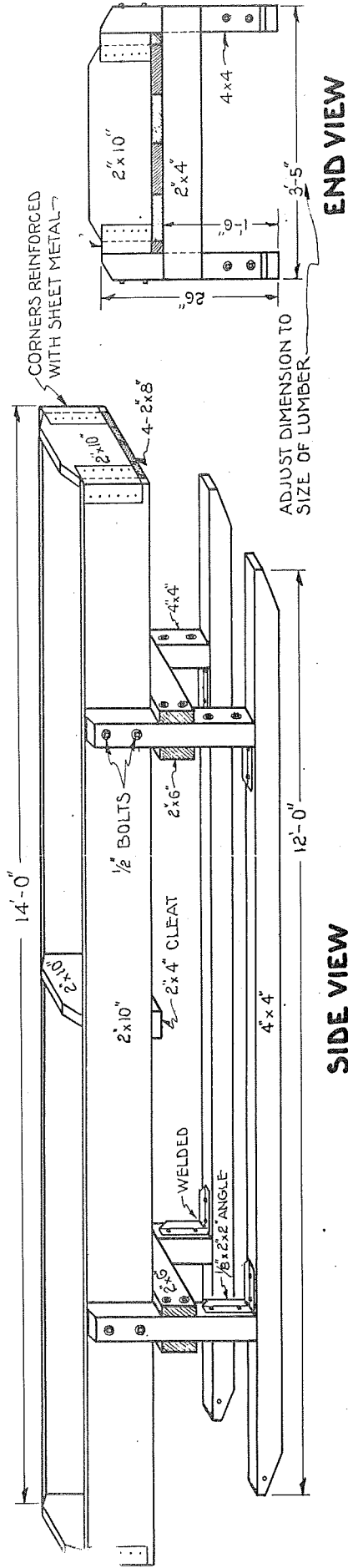

SIDE VIEW

END VIEW

PORTABLE GRAIN AND SILAGE FEED BUNK

CORNERS REINFORCED
WITH SHEET METAL

ADJUST DIMENSION TO
SIZE OF LUMBER.

BILLS OF MATERIAL

PORTABLE HAY-GRAIN OR SILAGE FEEDER

Lumber

2 pcs 4" x 4" x 16'-0" runners
 6 pcs 4" x 4" x 3'-8" posts
 4 pcs 2" x 10" x 4"-0" end boards
 2 pcs 2" x 2-1/3" x 4'-0" end boards
 3 pcs 2" x 6" x 4'-0" end and center boards
 2 pcs 2" x 12" x 14'-0" side boards
 2 pcs 2" x 10" x 14'-0" side boards
 2 pcs 2" x 6" x 14"-0" side boards
 56 sq. ft. floor material

Hardware

64 - 3/8" x 6" machine bolts
 128 washers
 2 lb. 16 d spikes
 2 lb. 8 d nails

PORTABLE GRAIN AND SILAGE FEED BUNK

Lumber

2 pcs 4" x 4" x 12'-0" runners
 4 pcs 4" x 4" x 2'-2" posts
 4 pcs 2" x 6" x 3'-6" cross braces
 1 pcs 2" x 4" x 2'-10" cleat
 2 pcs 2" x 10" x 14'-0" sides
 3 pcs 2" x 10" x 2'-9" ends and center pieces
 4 pcs 2" x 8" x 14'-0" floor of bunk

Hardware

8 - 1/2" x 6" machine bolt
 8 - 1/2" x 7-1/2" machine bolts
 16 - 3/8" x 5" machine bolts
 32 - 1/2" washers
 16 - 3/8" washers
 4 angle irons 1/8" x 2" x 2"-16" long
 4 pcs 6" x 9" x 20 guage sheet metal
 1 lb. 4 d nails
 2-1/2 lb. 16 d nails

PORTABLE HAY FEEDER

Bill of materials

Lumber

2 pcs. 4" x 4" x 16' - 0" runners
 6 pcs 4" x 4" x 15'-0" posts
 2 pcs 2" x 10" x 6'-0" feed trough
 2 pcs 2" x 10" x 14'-0" feed trough
 10 pcs 2" x 6" x 6'-0" end boards
 3 pcs 2" x 6" x 6'-0" runner braces
 2 pcs 2" x 4" x 6'-6" cross braces
 8 pcs 2" x 4" x 4'-6" side braces
 6 pcs 2" x 4" x 1'-6" side braces
 1 pcs 2" x 4" x 14'-0" floor joist
 3 pcs 2" x 4" x 5'-4" floor joist cross brace
 84 sq. ft. floor material
 31 pcs 2" x 6" x 6'-0" crib boards
 1 pc 4" x 4" x 14'-0" floor center piece

Hardware

12 - 3/8" x 6" machine bolts
 24 - 3/8" washers
 48 - 1/4" x 6" machine bolts
 96 - 1/4" washers
 5 lb. 16 d spikes
 3 lb. 10 d nails
 2 lb. 8 d nails

TOP EXTENSION

Lumber

6 pcs 4 x 4 x 5-0 posts
 2 pcs 2 x 6 x 14-0 side boards
 2 pcs 2 x 6 x 6'-8" side boards
 2 pcs 1 x 6 x 14-0 side boards
 2 pcs 1 x 6 x 6' x 8" side boards

Hardware

1 lb. 10 d nails
 12 - 1/2 x 8" machine bolts
 20 - 3/8" x 6" machine bolts
 24 - 1/2" washers
 40 - 3/8" washers

The extension on the portable hay feeder should be used whenever the feeder will be filled with a hydraulic fork. 1" x 6" crib boards and end boards can be substituted for the 2" x 6"'s shown if the extension will not be used. Pre-drill all holes for 16 d spikes with a 1/8" drill to avoid splitting the lumber. If spikes are substituted for bolts, use four 40 d spikes at each joint on the 2" x 10"'s and two 40 d spikes on each 2 x 6. Pre-drill all holes with a 3/16 drill to avoid splitting. Insert each spike in a 1/4 inch washer to give greater holding strength at the nail head.