

FLOOR PLAN

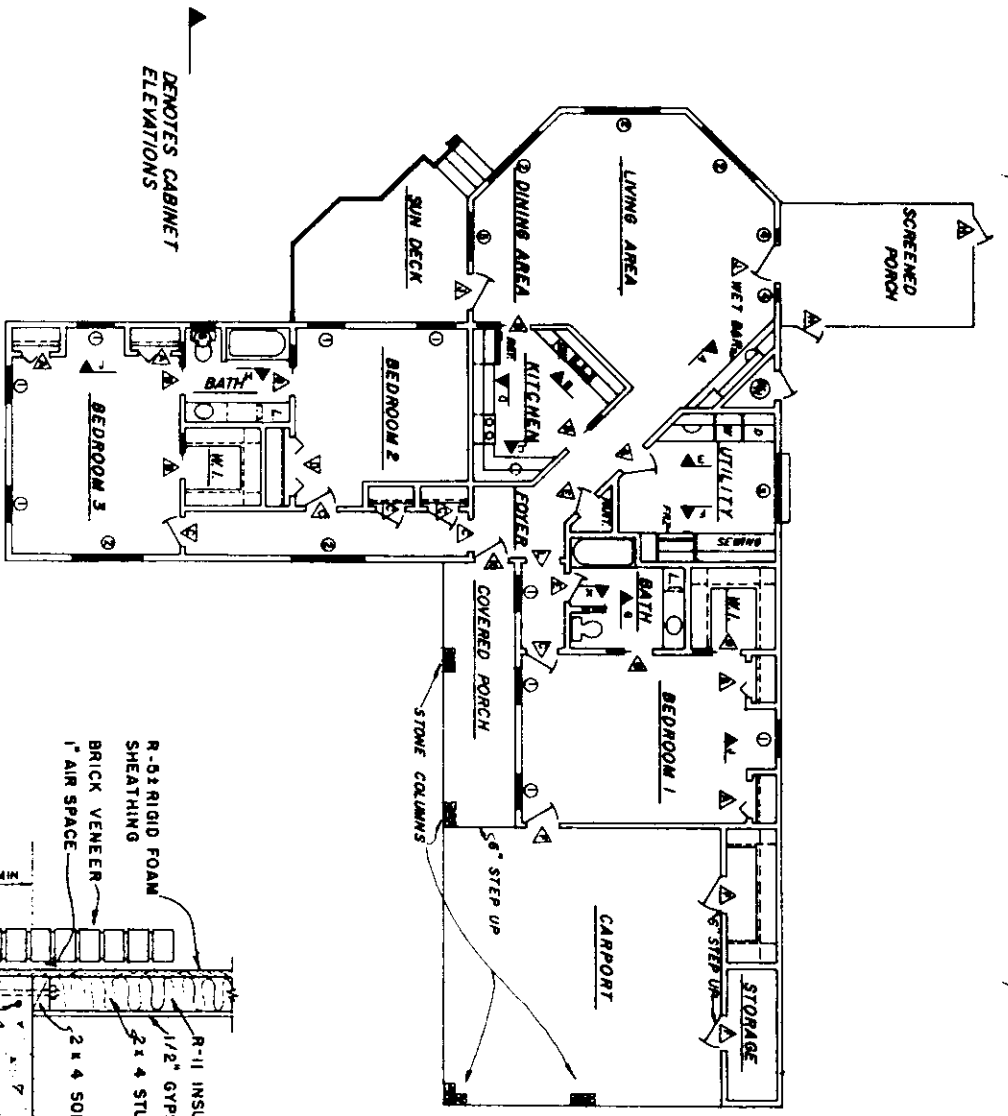

ALT. FOUNDATION DETAIL

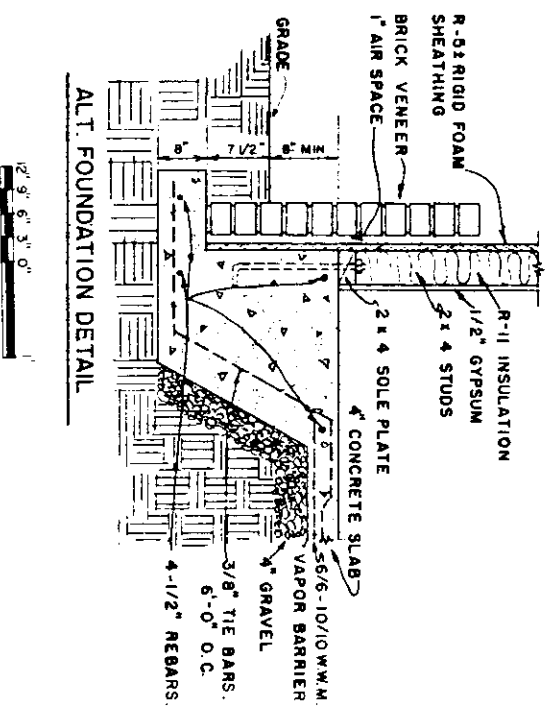

TYPICAL PIER DETAIL

NO SCALE

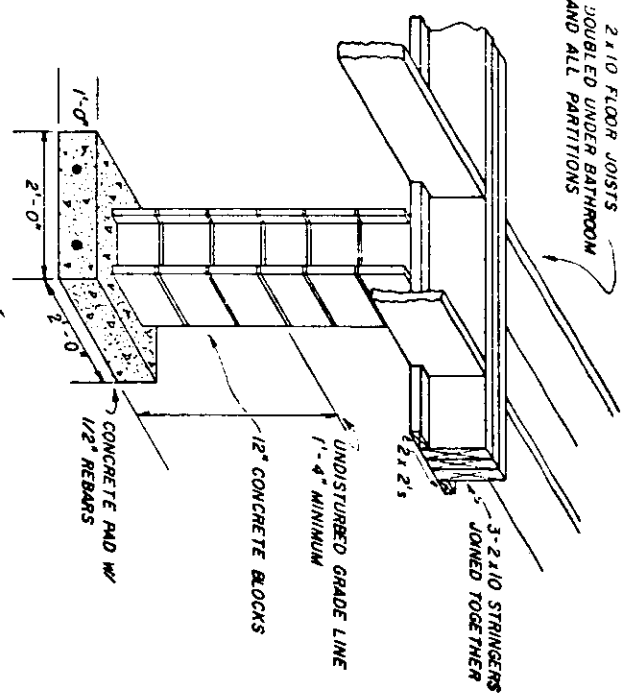

SCALE UNLESS OTHERWISE NOTED



COOPERATIVE EXTENSION WORK IN
AGRICULTURE AND HOME ECONOMICS

UNITED STATES DEPARTMENT OF AGRICULTURE
AND
NATIONAL AGRICULTURAL EXPERIMENT STATIONS

3 - BEDROOM CONTEMPORARY

MISS. '80 EX 7224 SHEET 1 OF 6

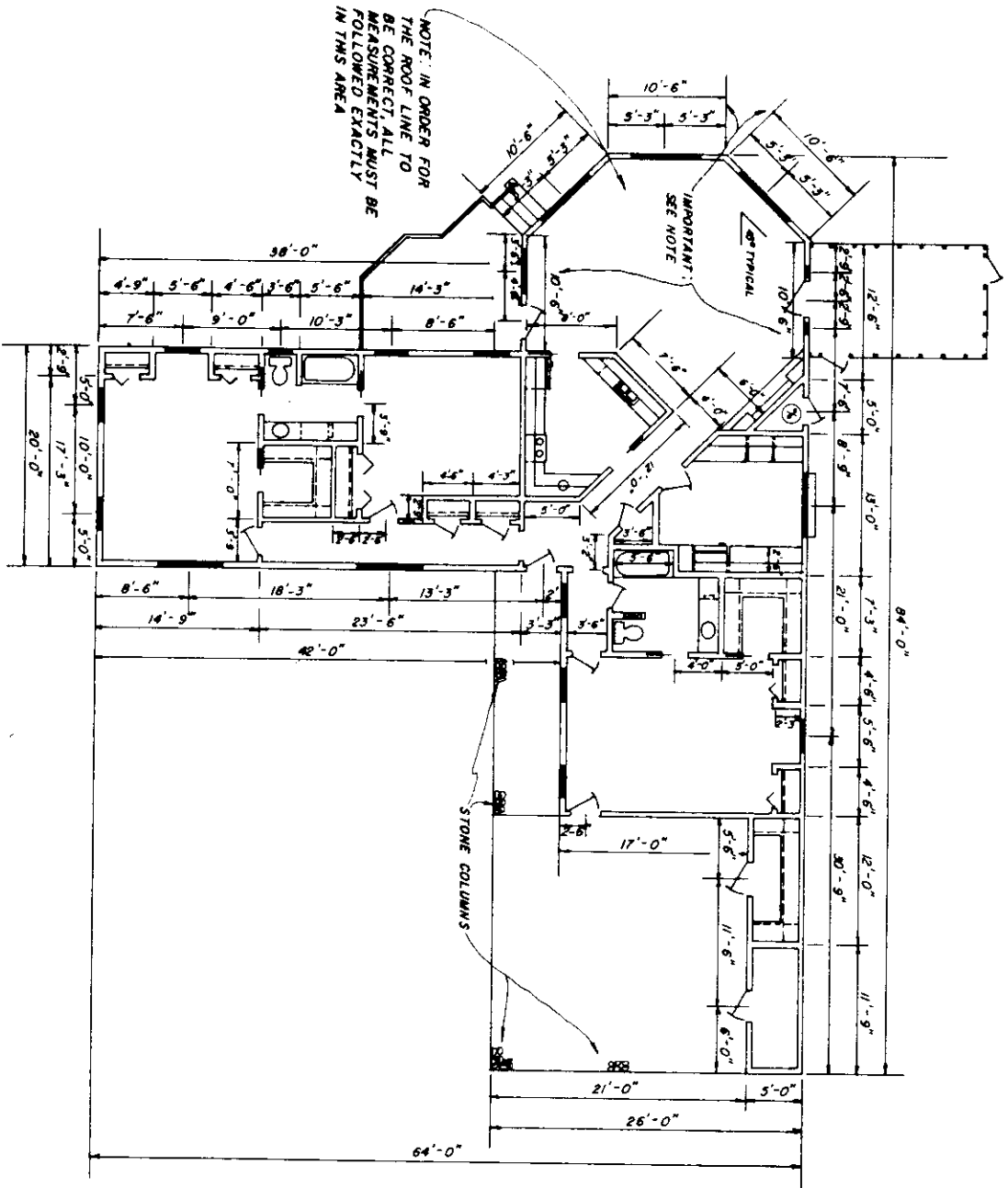

DIMENSION PLAN

30 x 42 : 845
 21 x 22 = 462
 3 x 20 = 60
 1952

DOOR SCHEDULE	
SYMBOL	DESCRIPTION
A	3'-0" X 8'-0" SINGLE BIFOLD PANEL
B	2'-4" X 6'-8" POCKET DOOR
C	2'-6" X 6'-8" SOLID CORE
D	5'-0" X 8'-0" DOUBLE BIFOLD
E	2'-4" X 6'-8" SOLID CORE
F	3'-0" X 6'-8" PLAIN INSULATED STEEL DOOR & FRAME, COMPLETE WITH DEAD BOLT, (DOOR VIEWER AT CARPORT ENTRY)
G	3'-0" X 6'-8" SOLID CORE
H	3'-0" X 6'-8" SCREENED ALUMINUM DOOR WITH BRONZE TONE FINISH TO MATCH WINDOWS
J	3'-0" X 6'-8" INSULATED STEEL DOOR WITH MULTIPLE TOP (COMPLETE WITH STEEL FRAME AND DEAD BOLT)
K	3'-0" X 6'-8" DECORATIVE INSULATED STEEL ENTRY DOOR COMPLETE WITH STEEL FRAME AND DEAD BOLT
L	2'-6" X 6'-8" FRAMED OPENING

WINDOW SCHEDULE	
SYMBOL	DESCRIPTION
1	3'-0" X 4'-0" CERTIFIED DOUBLE GLAZED CASHEMENT WITH BRONZE TONE ALUMINUM FRAME
2	6'-0" X 4'-0" CERTIFIED DOUBLE GLAZED CASHEMENT WITH BRONZE TONE ALUMINUM FRAME
3	5'-6" X 4'-0" GREENHOUSE WINDOW
4	1'-0" X 4'-0" CERTIFIED DOUBLE GLAZED CASHEMENT WITH BRONZE TONE ALUMINUM FRAME
5	4'-0" X 4'-0" CERTIFIED DOUBLE GLAZED CASHEMENT WITH BRONZE TONE ALUMINUM FRAME
6	2'-0" X 3'-0" CERTIFIED DOUBLE GLAZED CASHEMENT WITH BRONZE TONE ALUMINUM FRAME

COOPERATIVE EXTENSION WORK IN AGRICULTURE AND HOME ECONOMICS

UNITED STATES DEPARTMENT OF AGRICULTURE COOPERATING AND

3 - BEDROOM CONTEMPORARY

MISS. '80 EX. 7224 SHEET 2 OF 6

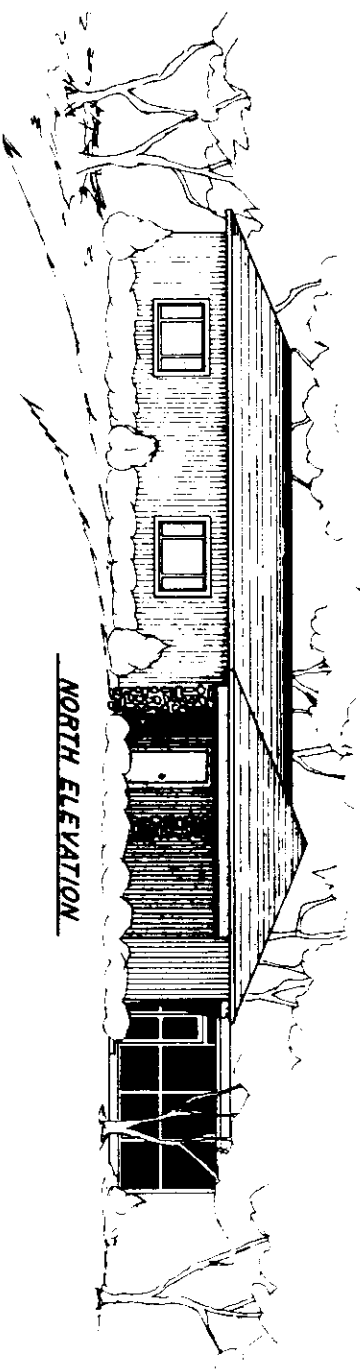

NORTH ELEVATION

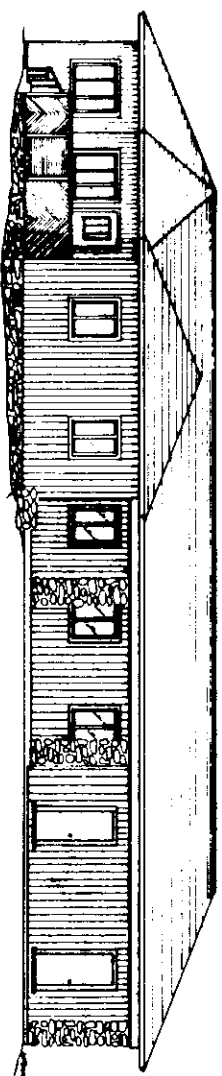

EAST ELEVATION

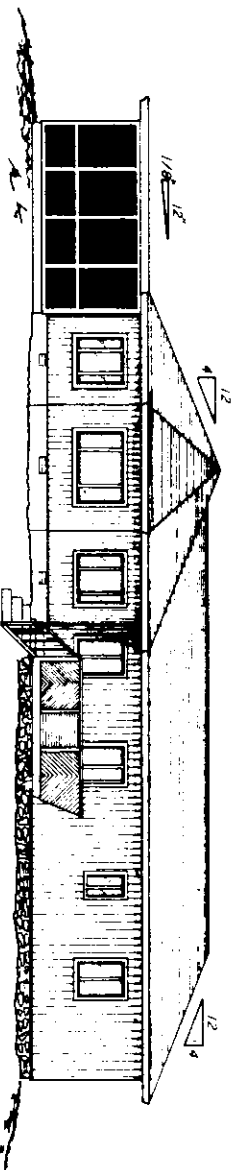

SOUTH ELEVATION

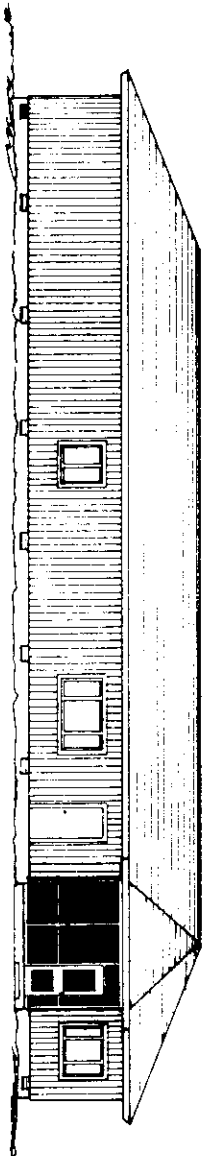

WEST ELEVATION

FOR OPTIMUM ENERGY
EFFICIENCY & LOWER
UTILITY COSTS, SITE
AS SHOWN

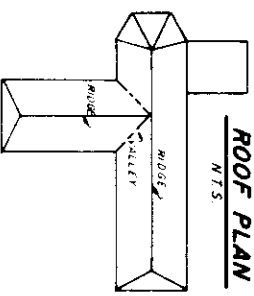

ROOF PLAN

HEATED SPACE	2132 SQ. FT.
CARPORT & STORAGE	618
PORCH	290
DECK	140



COOPERATIVE EXTENSION WORK IN
AGRICULTURE AND HOME ECONOMICS

AND
UNITED STATES DEPARTMENT OF AGRICULTURE COOPERATING

3 - BEDROOM CONTEMPORARY

MISS. '80 EX 7224 SHEET 3 OF 6

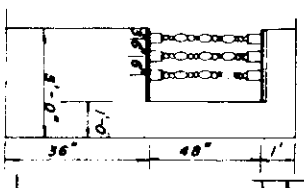
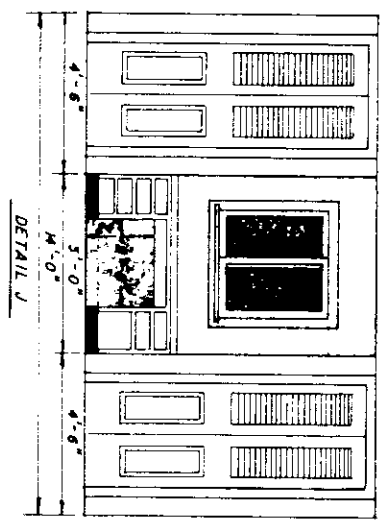
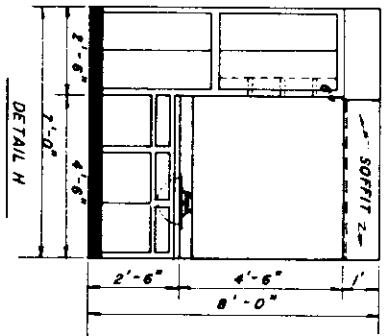
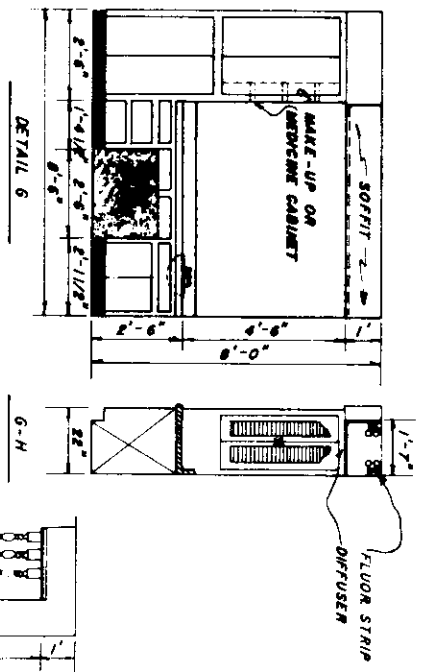
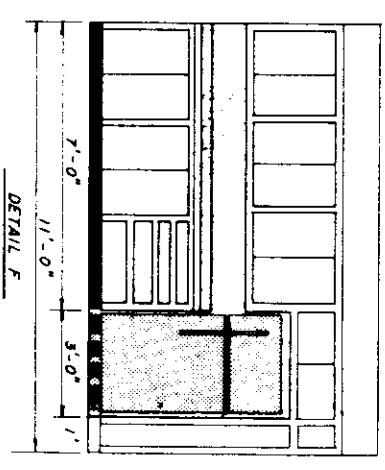
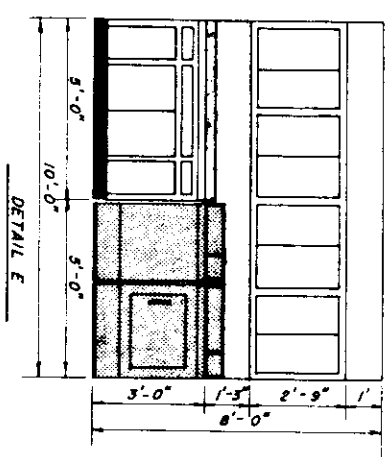
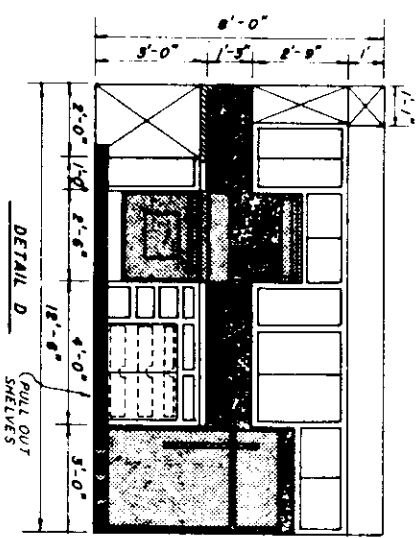
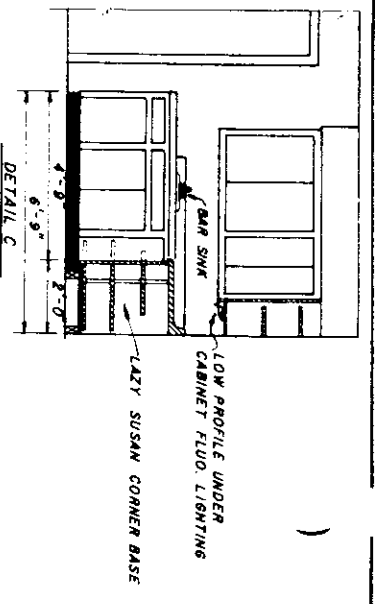
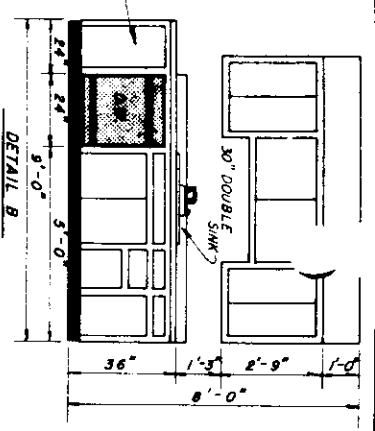
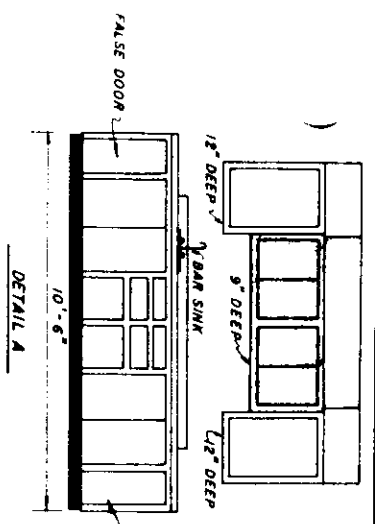

CABINET ELEVATIONS

SCALE:



COOPERATIVE EXTENSION WORK IN
AGRICULTURE AND HOME ECONOMICS

UNITED STATES DEPARTMENT OF AGRICULTURE COOPERATING

3 - BEDROOM CONTEMPORARY

MISS. '80 EX. 7224 SHEET 4 OF 6

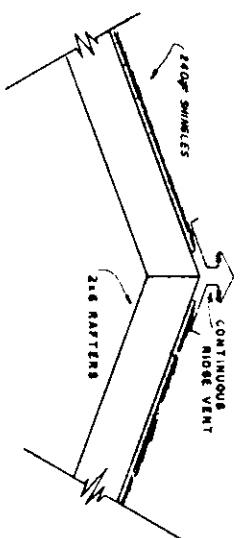

RIDGE VENT SECTION

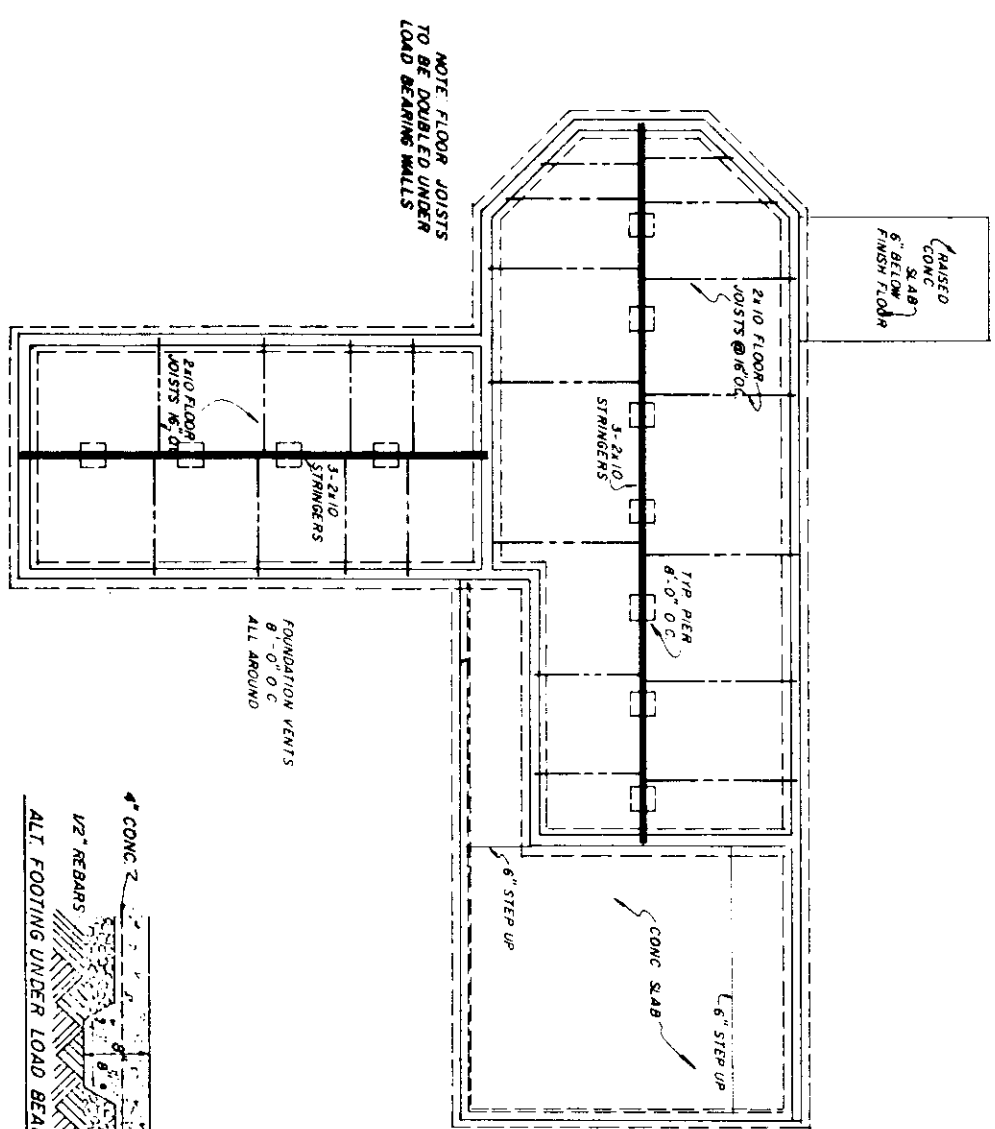

NOTE FLOOR JOISTS TO BE DOUBLED UNDER LOAD BEARING WALLS

FOUNDATION VENTS 8'-0" O.C. ALL AROUND

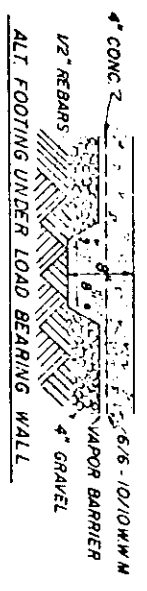

4" CONC. F. 1/2" REBARS 4" GRAVEL ALL FOOTING UNDER LOAD BEARING WALL.

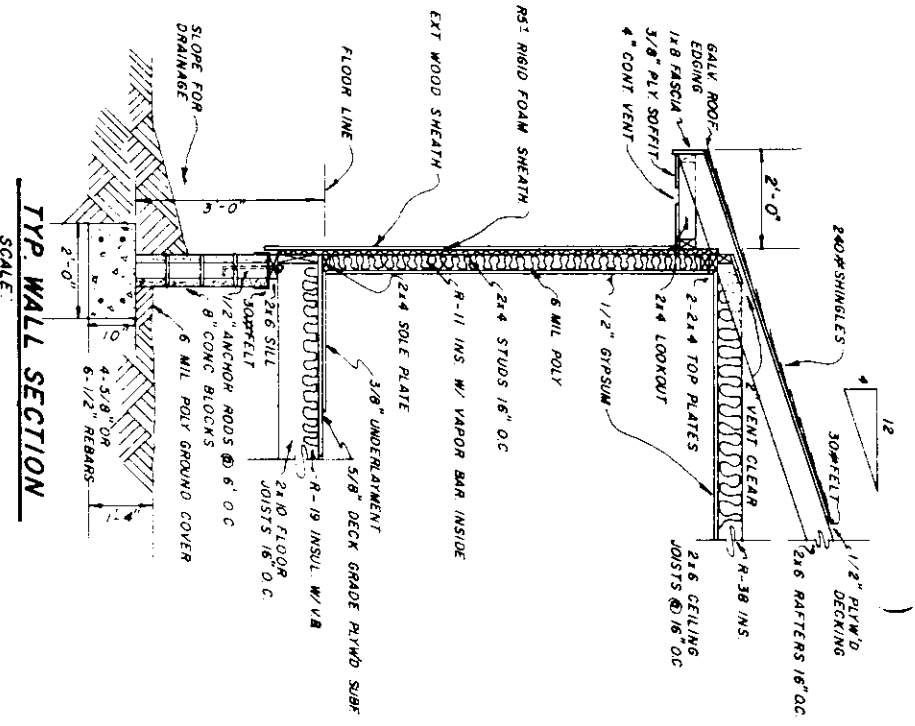

TYP. WALL SECTION

SCALE: 1/4" = 1'-0"

FOUNDATION PLAN

SCALE: 1/4" = 1'-0"

COOPERATIVE EXTENSION WORK IN AGRICULTURE AND HOME ECONOMICS

UNITED STATES DEPARTMENT OF AGRICULTURE COOPERATING AND

3-BEDROOM CONTEMPORARY

MISS. '60 EX. 7224 SHEET 5 OF 6

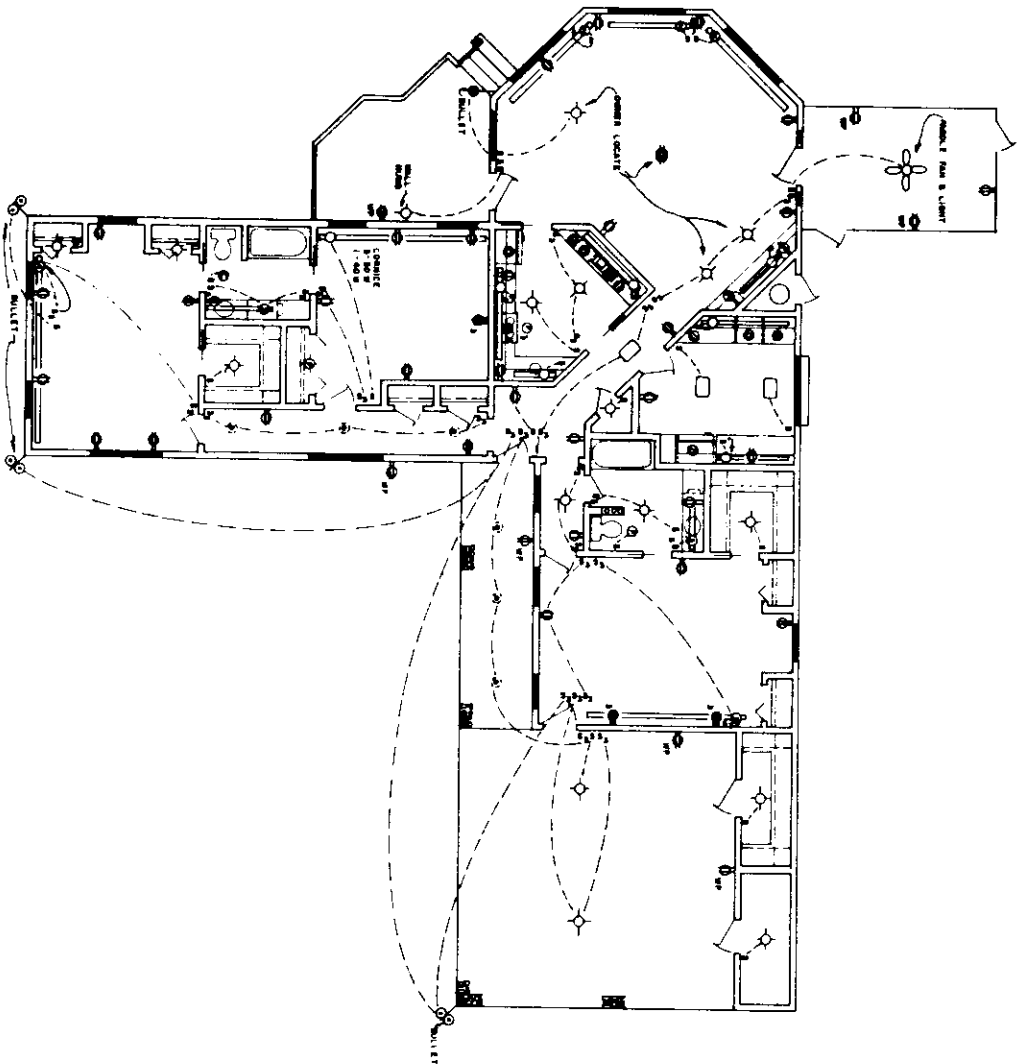

ELECTRICAL PLAN

ELECTRICAL SCHEDULE

SYM.	DESCRIPTION
S	SINGLE POLE SWITCH
S ₃	3-WAY SWITCH
○	LIGHTING OUTLET
□	FLUORESCENT STRIP UNDER CABINET, IN SOFFIT, OR IN CROWNICE. ALSO SHOWS NUMBER OF STRIPS INVOLVED.
□	1' x 4' SURFACE MOUNTED FLUORESCENT W/2 - 40W BULBS
○	RECESSED DOWNLIGHT
○	BULLET LIGHTING OUTLET
○	CEILING EXHAUST FAN
○	COMBINATION LIGHT & EXHAUST FAN
○	110 VOLT 20 AMP. DUPLEX OUTLET
○	110 VOLT 20 AMP. TRIPLEX OUTLET
○	SPLIT WIRED RECEPTACLE
○	SPECIAL PURPOSE 110 VOLT OUTLET
○	SPECIAL PURPOSE 240 VOLT OUTLET
○	DUPLEX FLOOR RECEPTACLE
○	WEATHERPROOF CONVENIENCE OUTLET
○	RANGE OUTLET

*NOTE: EXACT LOCATIONS OF FIXTURES SHALL BE DETERMINED BY OWNER.
 UNDERCABINET LIGHTING IN KITCHEN SHALL BE SIZED ACCORDING TO FINISHED SPACE.
 OWNER WILL DECIDE OUTSIDE FLOOD LIGHTING AND PROVIDE SWITCHING FOR SAME.

SCALE:



COOPERATIVE EXTENSION WORK IN
 AGRICULTURE AND HOME ECONOMICS

UNIVERSITY OF CALIFORNIA
 AND
 UNITED STATES DEPARTMENT OF AGRICULTURE COOPERATING

3 - BEDROOM CONTEMPORARY
 MISS. '80 EX. 7224 SHEET 6 OF 6