

FLOOR PLAN
 1/2" = 1'-0"
 SCALE

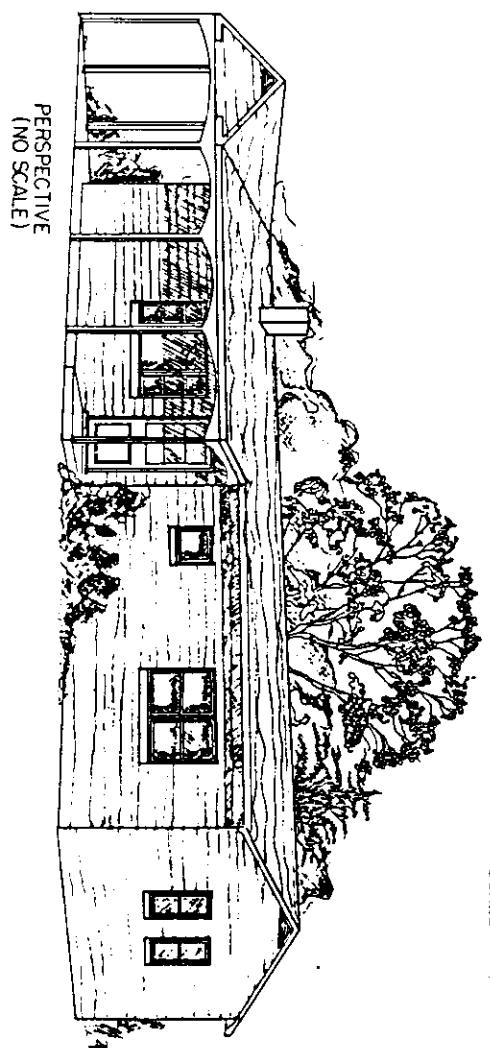

PERSPECTIVE
 (NO SCALE)

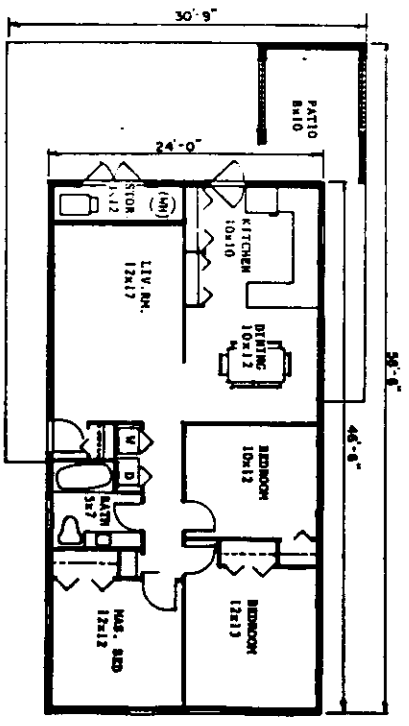

ALTERNATE FLOOR PLAN
 1/2" = 1'-0"
 SCALE

COOPERATIVE EXTENSION SERVICE
 AGRICULTURE AND HOME ECONOMICS

UNITED STATES DEPARTMENT OF AGRICULTURE COOPERATING

3 BEDROOM FARMHOUSE

USDA 1963 7167 SHEET 1 OF 3

REV. 87

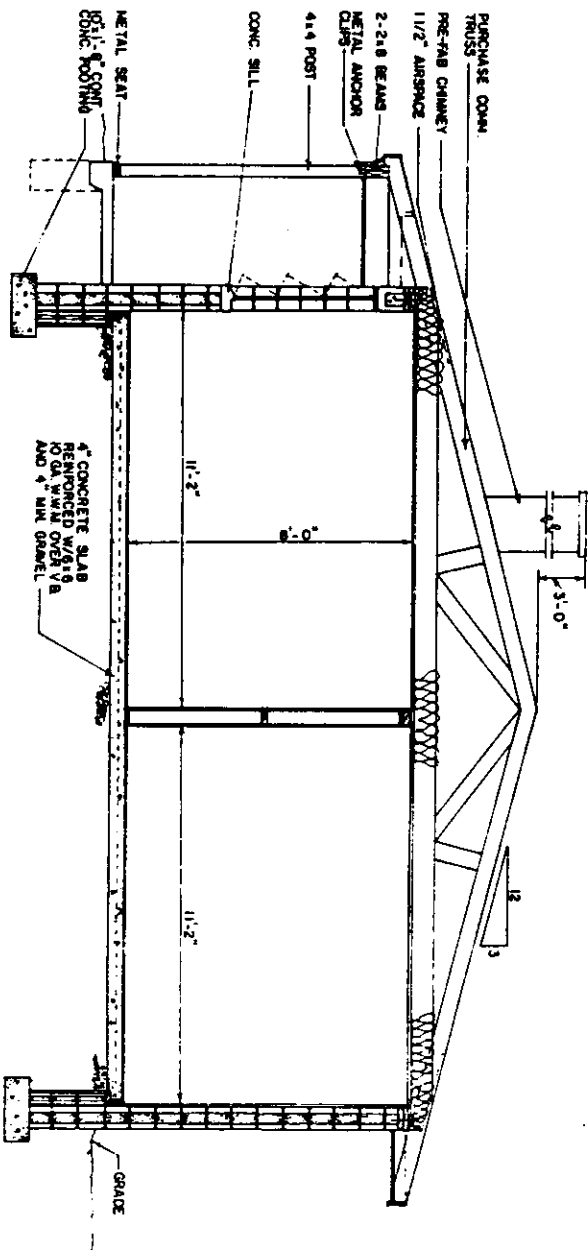

CROSS SECTION A-A
 1" = 5'-0" SCALE

CONSTRUCTION CHECK LIST

1. CHECK LOCAL BUILDING AND LOAN COMPANY CRITERIA. PURCHASE TRUSSES TO MEET LOCAL SNOW LOAD CRITERIA.
2. ADEQUATELY NAIL AND ANCHOR JOINTS.
3. SHEATH ALL CORNERS WITH 1/2" PLYWOOD OR HIGH DENSITY FIBERBOARD OR USE DIAGONAL BRACING.
4. PRESSURE TREAT ALL WOOD WITH GROUND CONTACT WHEREVER IT MAY BE METTED DURING OR AFTER CONSTRUCTION.
5. INSULATION NETS DEPEND ON LOCAL CLIMATE AND FUEL COSTS. FILLING CONES OF CONCRETE BLOCKS WITH VERMICULITE (OR EQUAL) WILL PROVIDE R-5. EACH INCH OF EXPANDED POLYSTYRENE (STYROFOAM) BOARD WILL ADD 4 TO 5 TO THIS R VALUE. A TOTAL OF R-11 IS CONSIDERED MINIMUM FOR MOST CLIMATES.
7. PROVIDE 1 SQ FT OF ATTIC VENT OPENINGS FOR EACH 150 SQ FT OF CEILING.
8. WEATHERIZE ALL OPENINGS AND JOINTS.

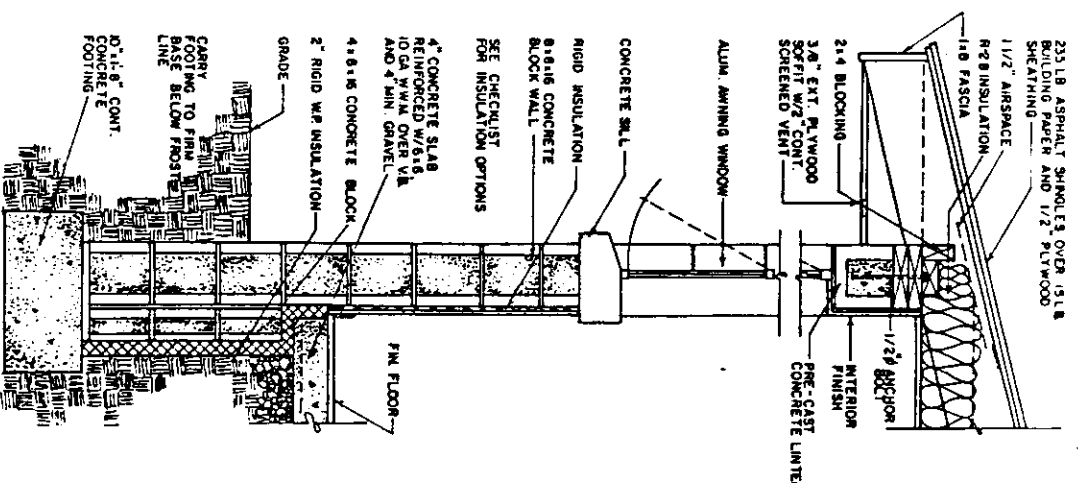

TYPICAL WALL SECTION
 1" = 5'-0" SCALE

UNITED STATES DEPARTMENT OF AGRICULTURE COOPERATING		
COOPERATIVE EXTENSION SERVICE AGRICULTURE AND HOME ECONOMICS		
3 BEDROOM FARMHOUSE		
USDA 1963	767	SHEET 3 OF 3
REV. 87		