

• FLOOR PLAN •  
SCALE 1/4"=1'-0"

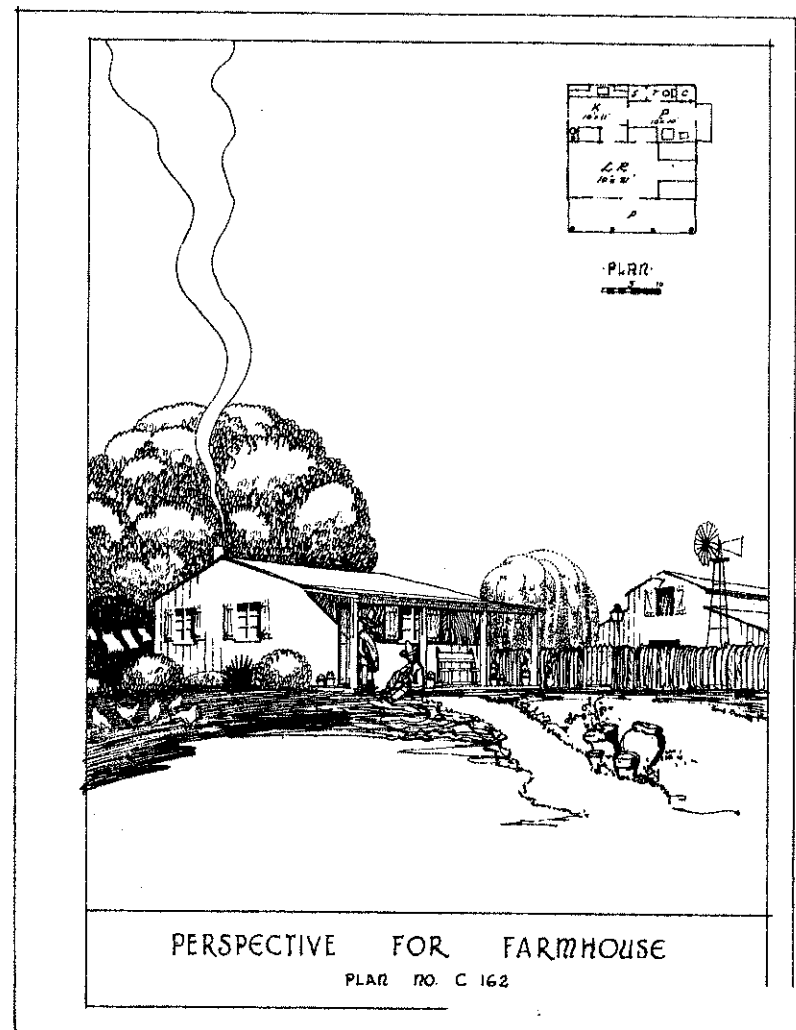

PERSPECTIVE FOR FARMHOUSE  
PLAN NO. C 162

• ELECTRICAL

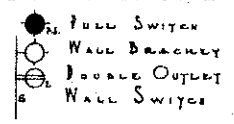

PLAN PREPARED UNDER THE RURAL HOUSING PROJECT - BUREAU OF HOME ECONOMICS AND AGRICULTURAL ENGINEERING - U.S. DEPARTMENT OF AGRICULTURE AND CIVIL WORKS ADMINISTRATION COOPERATING.

COOPERATIVE EXTENSION WORK IN AGRICULTURE AND HOME ECONOMICS  
STATE OF NORTH DAKOTA  
NORTH DAKOTA AGRICULTURAL COLLEGE  
AND  
U.S. DEPT. OF AGRICULTURE COOPERATING.  
EXT. AGR'L. ENGINEER- FARGO, N. DAK.

**FARM HOUSE**

CALIF. '34 EX. 6504 SHEET 1 OF 5

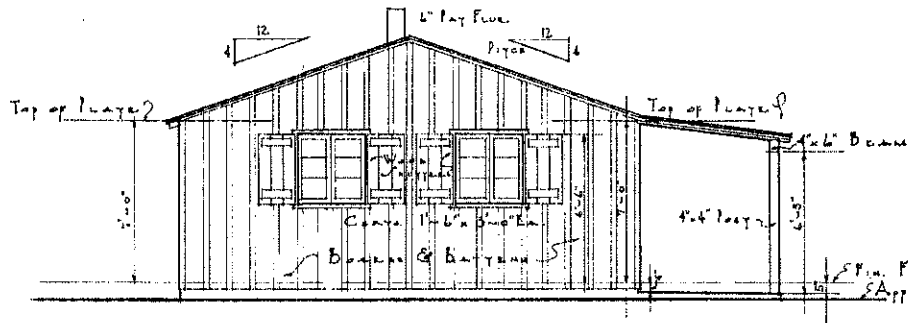

• SIDE ELEVATION •  
SCALE 1/4" = 1'-0"

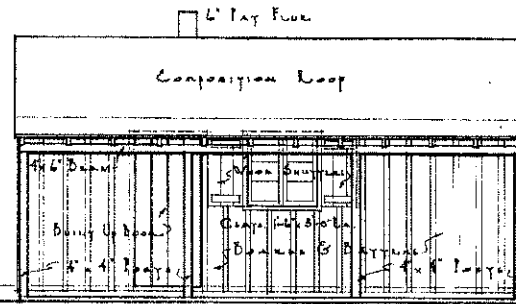

• FRONT ELEVATION •  
SCALE 1/4" = 1'-0"

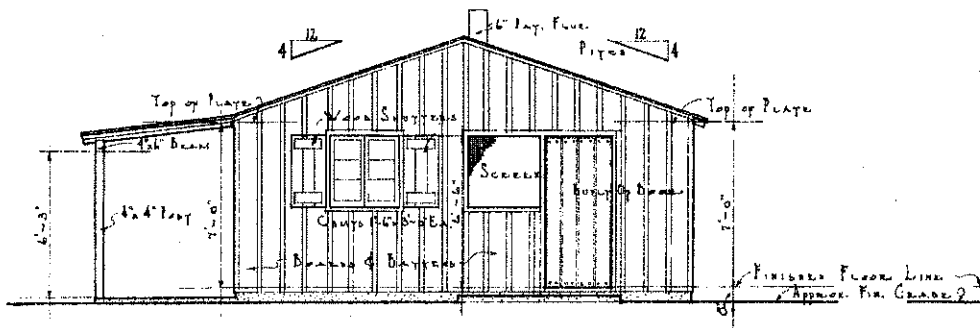

• SIDE ELEVATION •  
SCALE 1/4" = 1'-0"

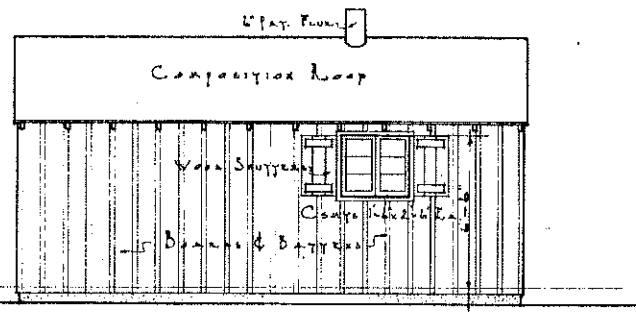

• REAR ELEVATION •  
SCALE 1/4" = 1'-0"

COOPERATIVE EXTENSION WORK IN  
AGRICULTURE AND HOME ECONOMICS  
STATE OF NORTH DAKOTA  
NORTH DAKOTA AGRICULTURAL COLLEGE  
AND  
U.S. DEPT. OF AGRICULTURE COOPERATING.  
EXT. AGR'L. ENGINEER- FARGO, N. DAK.

**FARM HOUSE**

CALIF. 134 EX. 6504 SHEET 2 OF 5

PLAN PREPARED UNDER THE RURAL HOUSING  
PROJECT - BUREAUS OF HOME ECONOMICS AND  
AGRICULTURAL ENGINEERING - U.S. DEPARTMENT  
OF AGRICULTURE AND CIVIL WORKS  
ADMINISTRATION COOPERATING.

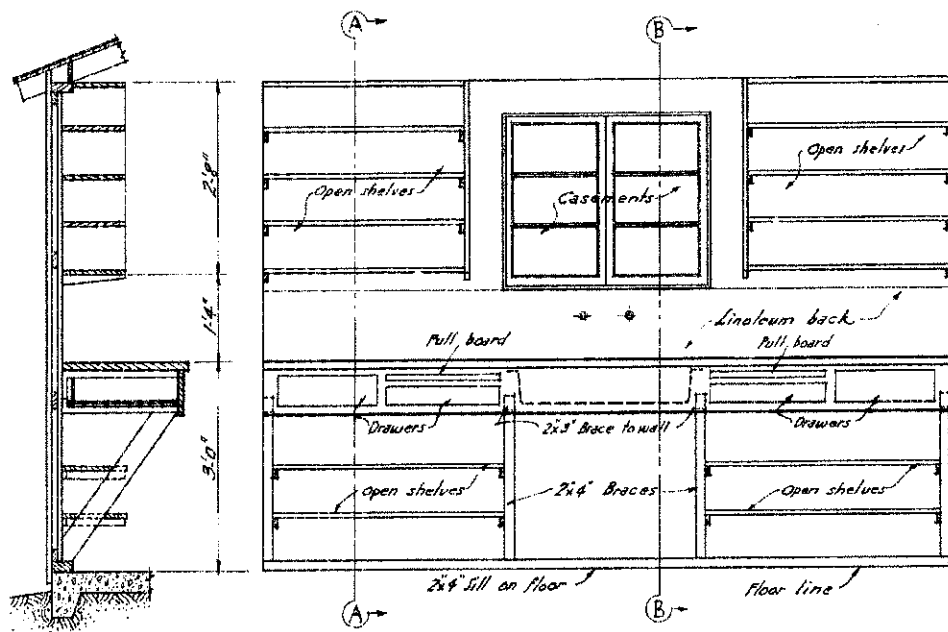

SECTION A-A

ELEVATION OF SINK CASE  
Scale  $\frac{3}{4}'' = 1'-0''$

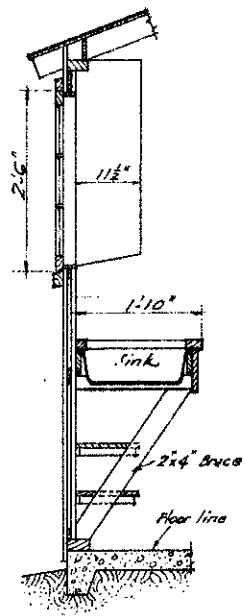

SECTION B-B

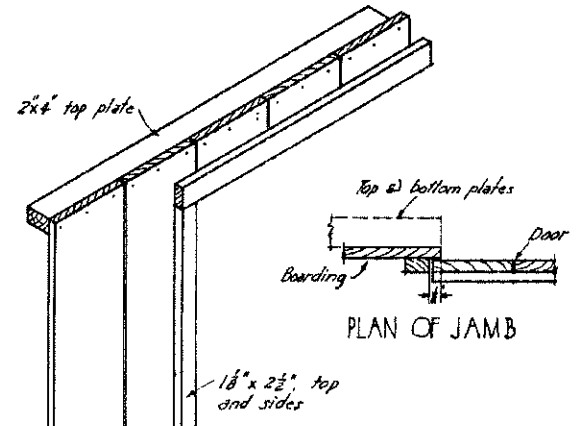

PLAN OF JAMB

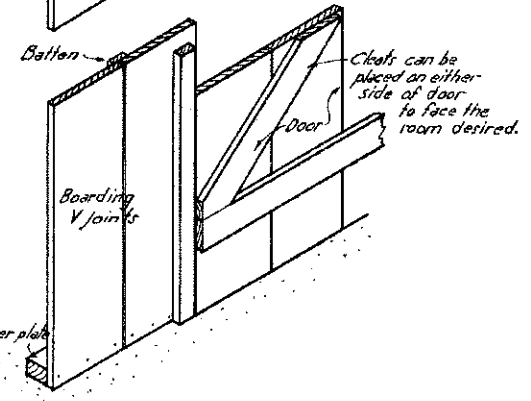

ISOMETRIC OF INTERIOR PARTITION  
Scale  $\frac{1}{2}'' = 1'-0''$

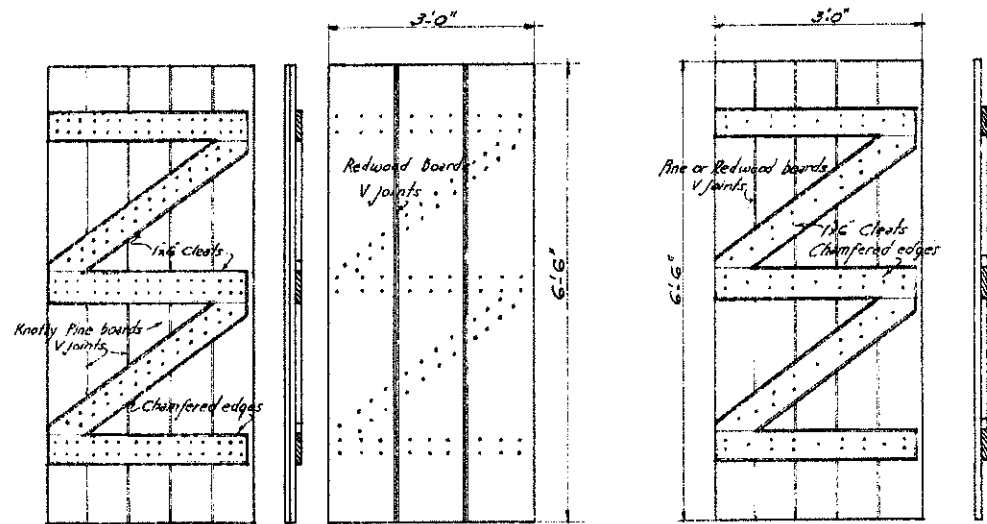

INTERIOR SECT. EXTERIOR  
MAIN ENTRANCE DOOR

INTERIOR DOOR

Scale  $\frac{3}{4}'' = 1'-0''$

TYPICAL INTERIOR DETAILS

PLAN PREPARED UNDER THE RURAL HOUSING PROJECT - BUREAU OF HOME ECONOMICS AND AGRICULTURAL ENGINEERING - U.S. DEPARTMENT OF AGRICULTURE AND CIVIL WORKS ADMINISTRATION COOPERATING.

COOPERATIVE EXTENSION WORK IN AGRICULTURE AND HOME ECONOMICS STATE OF NORTH DAKOTA NORTH DAKOTA AGRICULTURAL COLLEGE AND U.S. DEPT. OF AGRICULTURE COOPERATING. EXT. AGR'L. ENGINEER- FARGO, N. DAK.

TYPICAL DETAILS  
CALIF. 34 EX. 6504-05 SHEET 3 OF 5

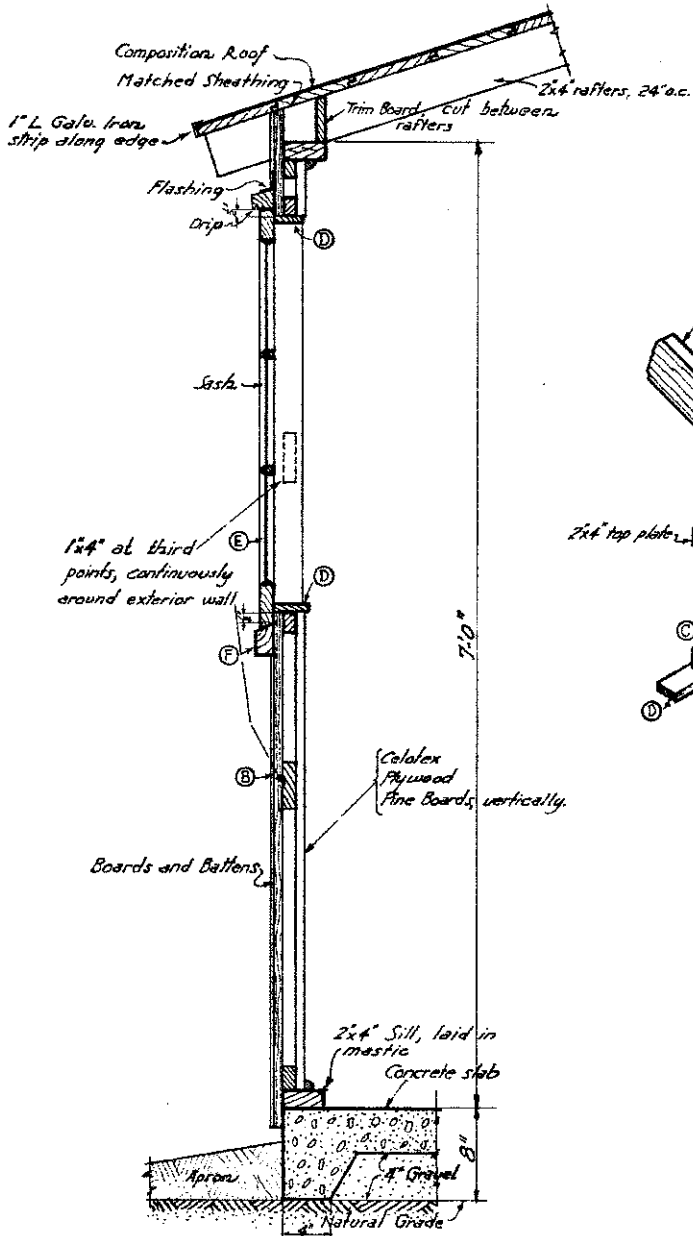

**WALL SECTION**  
Scale 1/2" = 1'-0"

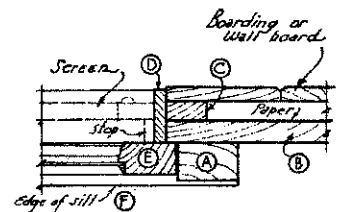
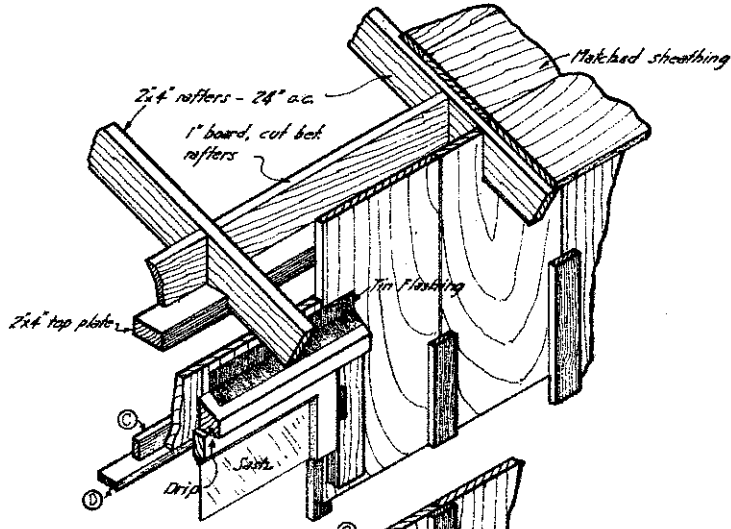

**PLAN THRU JAMB**  
Scale 3" = 1'-0"

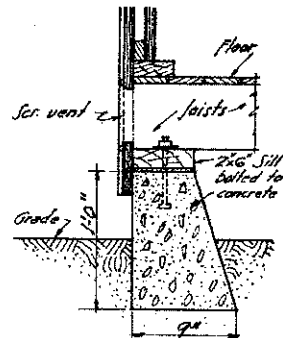
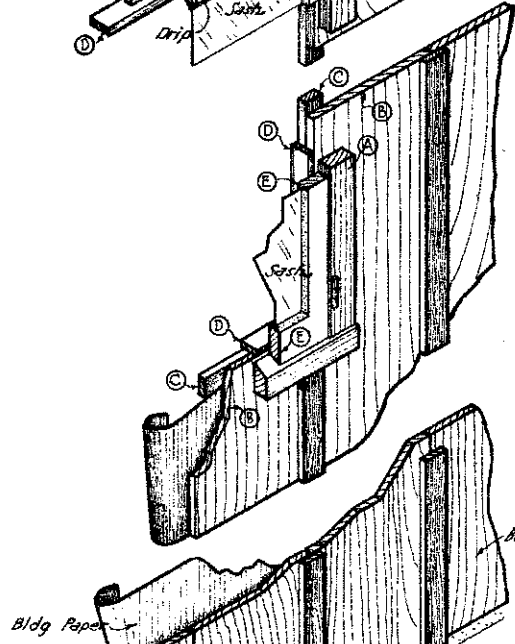

**ALTERNATE DETAIL FOR JOIST CONSTRUCTION**

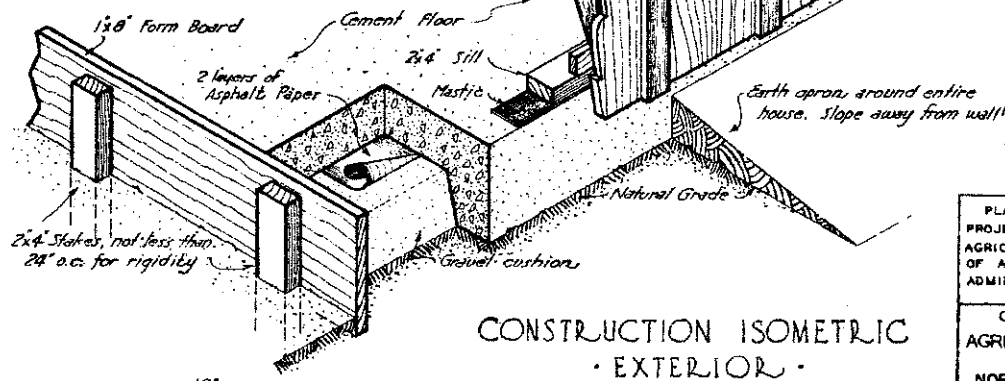

**CONSTRUCTION ISOMETRIC - EXTERIOR**  
Scale 1/2" = 1'-0"



**WITH SLEEPERS @ FLOORING**

PLAN PREPARED UNDER THE RURAL HOUSING PROJECT - BUREAUS OF HOME ECONOMICS AND AGRICULTURAL ENGINEERING - U.S. DEPARTMENT OF AGRICULTURE AND CIVIL WORKS ADMINISTRATION COOPERATING.

COOPERATIVE EXTENSION WORK IN AGRICULTURE AND HOME ECONOMICS STATE OF NORTH DAKOTA NORTH DAKOTA AGRICULTURAL COLLEGE AND U.S. DEPT. OF AGRICULTURE COOPERATING. EXT. AGR'L. ENGINEER - FARGO, N. DAK.

**TYPICAL DETAILS**

CALIF. '34 EX 6504-05 SHEET 4 OF 5

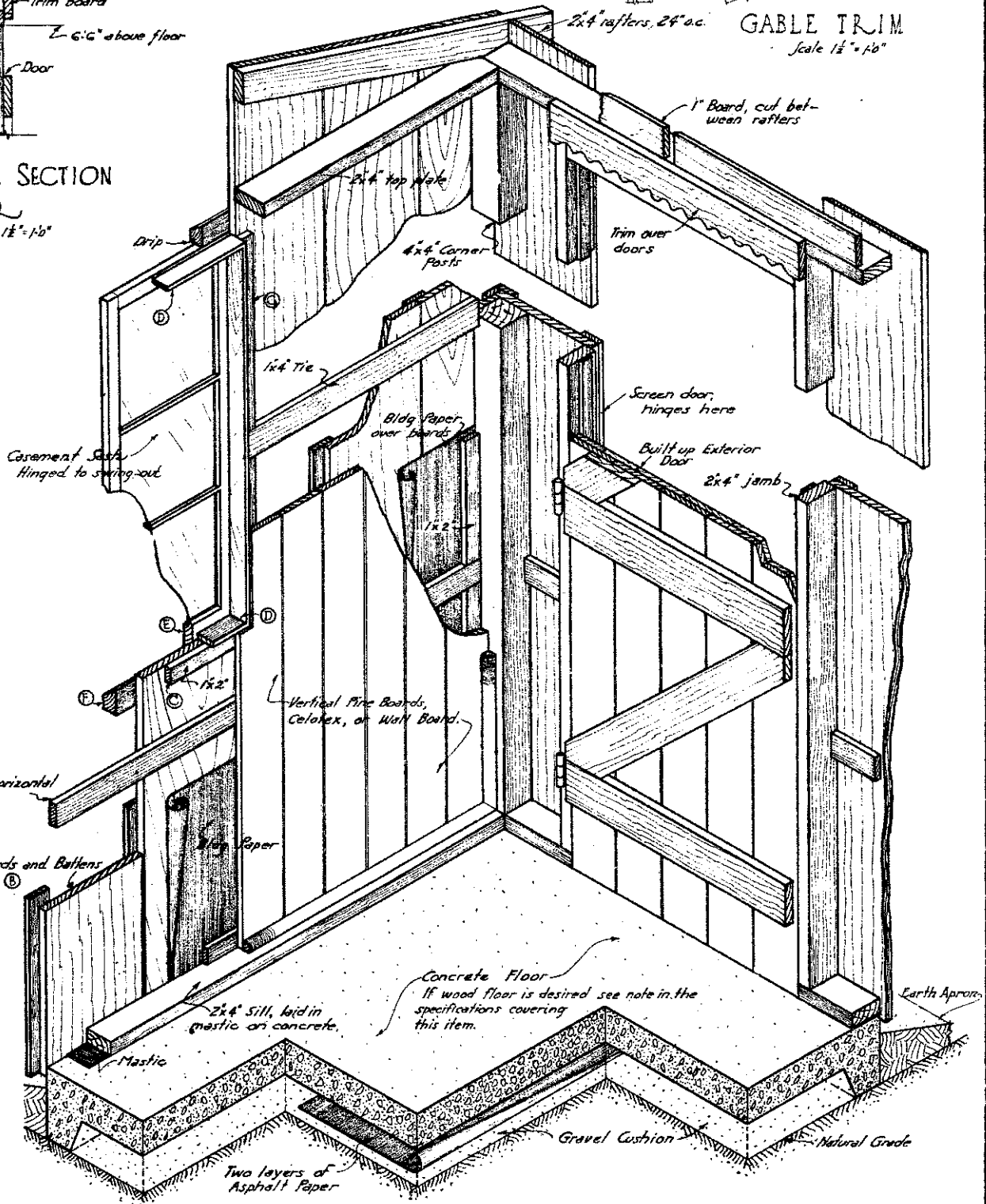
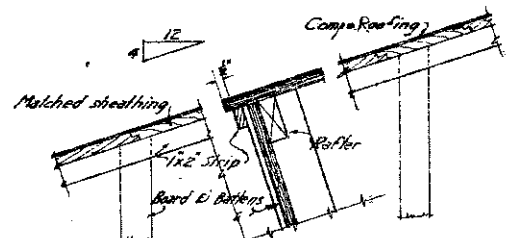
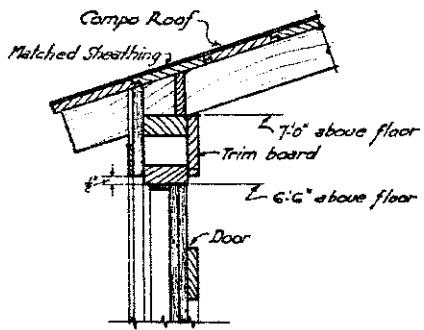

PLAN PREPARED UNDER THE RURAL HOUSING PROJECT - BUREAU OF HOME ECONOMICS AND AGRICULTURAL ENGINEERING - U.S. DEPARTMENT OF AGRICULTURE AND CIVIL WORKS ADMINISTRATION COOPERATING.

COOPERATIVE EXTENSION WORK IN AGRICULTURE AND HOME ECONOMICS  
STATE OF NORTH DAKOTA  
NORTH DAKOTA AGRICULTURAL COLLEGE  
AND  
U.S. DEPT. OF AGRICULTURE COOPERATING,  
EXT. AGRIC. ENGINEER FARRON, M.D.M.  
**TYPICAL DETAILS**  
CALIF. '34 EX. 6504-05 SHEET 5 OF 5