

FLUSH BOX DETAIL

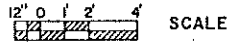

DUMP WELL DETAIL



NOTE:
INSULATION JOINTS TO BE TONGUE & GROOVE OR TAPED WITH VAPOR RESISTANT TAPE. MOLDED BEAD STYRENE IS NOT RECOMMENDED

NOTE:
ORDER TRUSS TO MEET LOCAL ROOF LOAD CONDITIONS

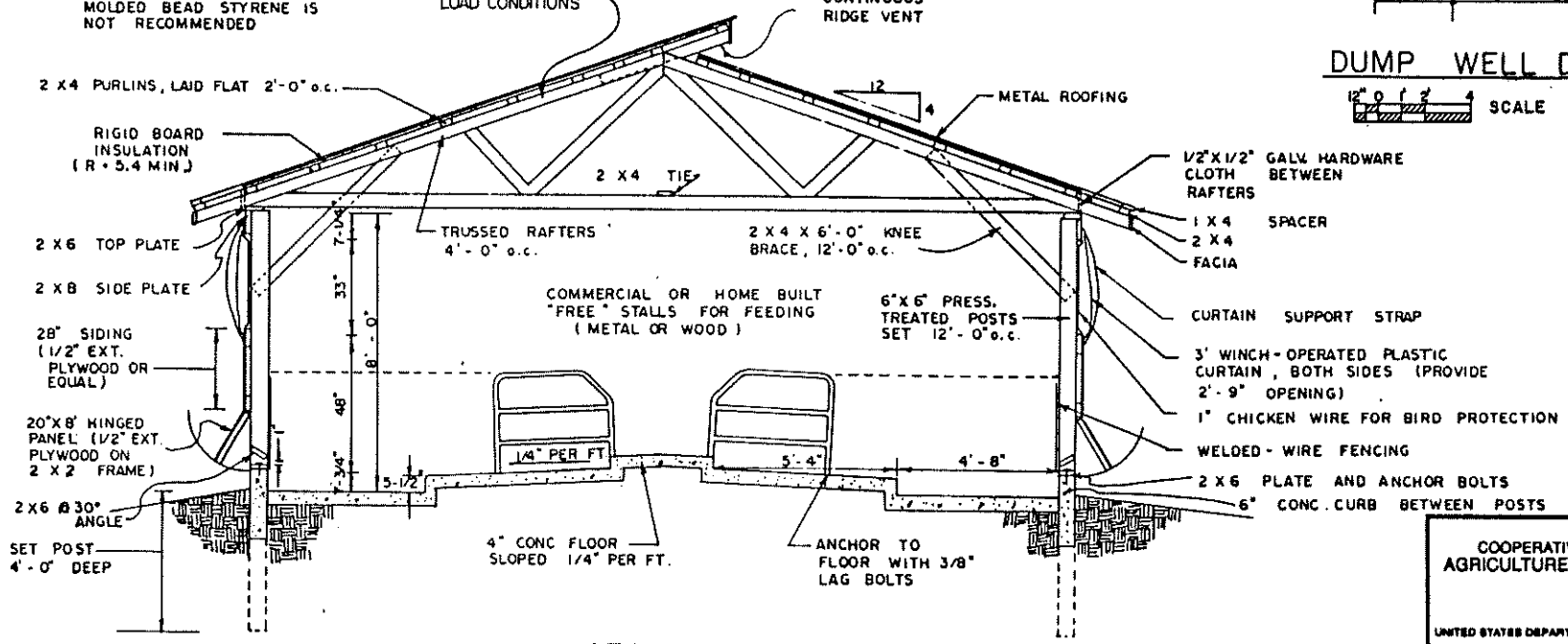

SECTION A-A

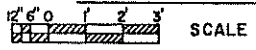

NOTE:
SOWS ARE TO BE GROUPED 6 PER PEN

COOPERATIVE EXTENSION SERVICE AGRICULTURE AND HOME ECONOMICS		
UNITED STATES DEPARTMENT OF AGRICULTURE COOPERATING		
SWINE GESTATION HOUSE WITH FEEDING STALLS-CURTAIN WALL		
TN. '88	6400	SHEET 1 OF 2

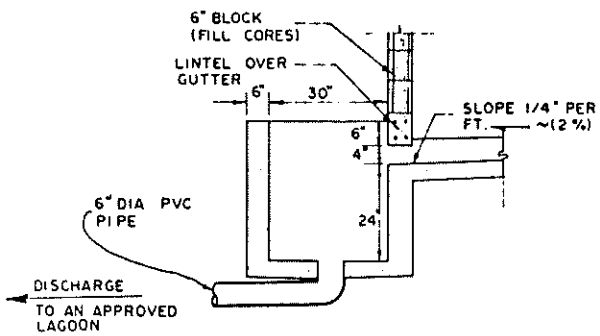

SECTION B-B

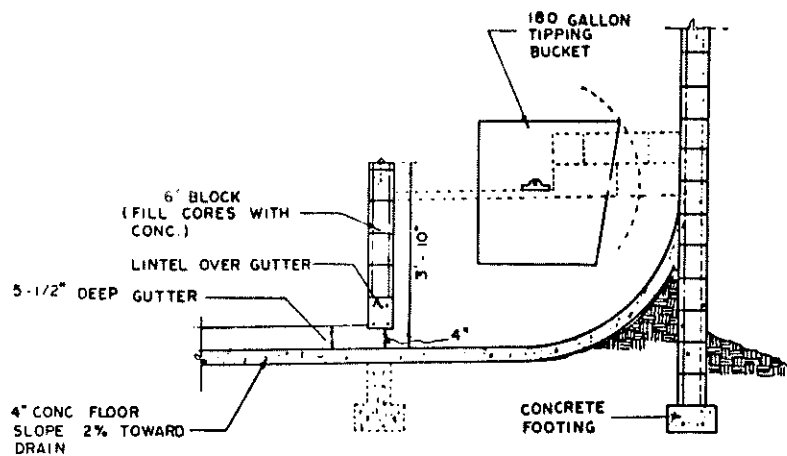
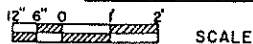

SECTION C-C

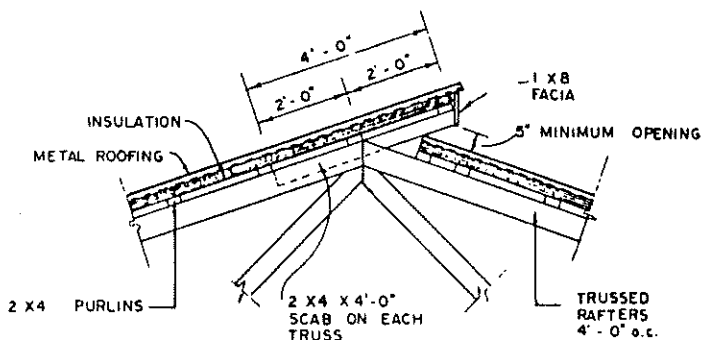
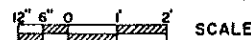

RIDGE VENT DETAIL

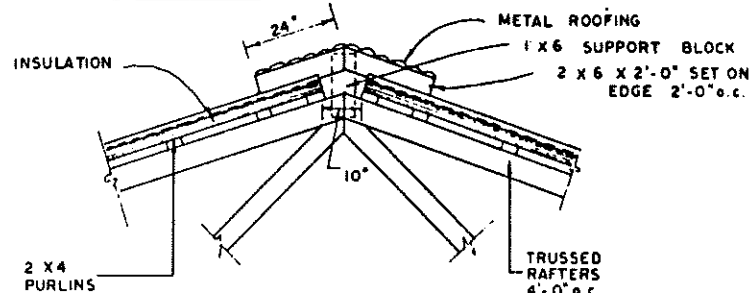
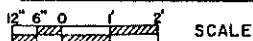

ALTERNATE RIDGE VENT

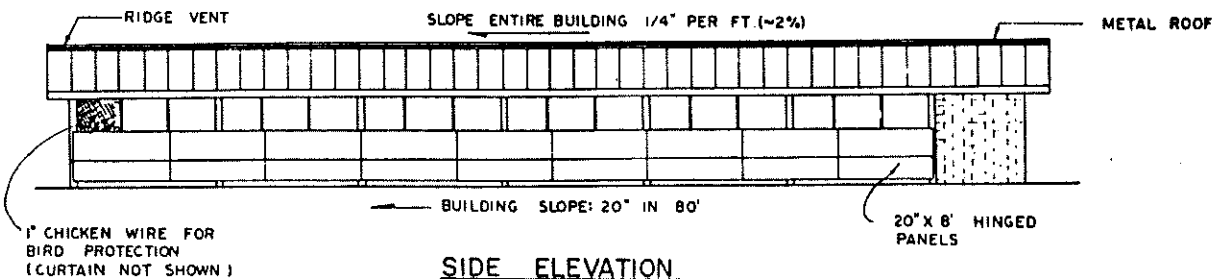
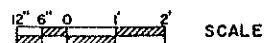

SIDE ELEVATION

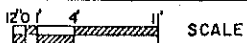

COOPERATIVE EXTENSION SERVICE
AGRICULTURE AND HOME ECONOMICS

AND
UNITED STATES DEPARTMENT OF AGRICULTURE COOPERATING

SWINE GESTATION HOUSE WITH
FEEDING STALLS-CURTAIN WALL

TN. '88 6400 SHEET 2 OF 2