

FRONT VIEW

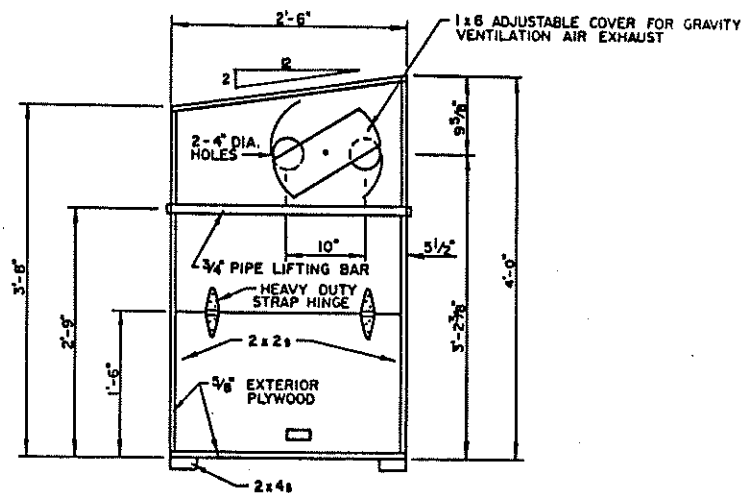

SIDE VIEW



SCALE

NOTE: THIS WARMING BOX IS SUITABLE FOR BOTH INDOOR AND OUTDOOR USE. PRESERVATIVE PRESSURE TREATED LUMBER SHOULD BE USED THROUGHOUT AND WATERPROOFING PROVIDED IF USED OUTDOORS.

THIS UNIT WAS SPECIFICALLY DESIGNED TO PROVIDE A FAVORABLE ENVIRONMENT FOR WEAK DAIRY AND BEEF CALVES OR THOSE CALVES BORN UNDER ADVERSE TEMPERATURE CONDITIONS. USE THE FOLLOWING PROCEDURES:

1. FEED CALF 2 QUARTS OF COLOSTRUM IMMEDIATELY FOLLOWING BIRTH AND AGAIN A 6, 12, AND 18 HOURS.
2. ADMINISTER VETERINARIAN PRESCRIBED MEDICINES AND VACCINATIONS.
3. APPLY NAVAL CLIP AND OR DIP IN IODINE.
4. PLACE CALF IN PREWARMED CALF WARMING BOX AND MAINTAIN 90 F TEMPERATURE.
5. OBSERVE CALF PERIODICALLY FOR ACTIVITY AND PROGRESS OF DRYING. REMOVE CALF WHEN DRY.
6. BRUSH HAIR COAT ERECT.
7. PLACE CALF ON WELL BEDDED OUTSIDE MANAGEMENT PROGRAM.
8. CONTINUE WITH RECOMMENDED CALF MANAGEMENT PROGRAM.

APPROXIMATE BILL OF MATERIALS	
NUMBER	DESCRIPTION
4	2x4x8' - RUNNERS AND FLOOR SUPPORTS
4	2x2x6' - FRAMEWORK
1	1x6x2' - ADJUSTABLE COVER
3	1x3x8' - DOOR STOP, LATCHES AND FLOOR EDGE
3	5/8x4x8'- EXTERIOR PLYWOOD -SIDES, ROOF AND FLOOR
2	6" HEAVY DUTY STRAP HINGE- CALF DOOR FRONT
2	4" HEAVY DUTY STRAP HINGE- REMOVAL CLEANING DOOR
2	2" LIGHT DUTY HINGES- HEATER DOOR
1	1/8" EXPANDED METAL 3'x 3'- FAN, LIGHT COVER AND HEATER COMPARTMENT DOOR
1	2'-2' x 3'-8" PLASTIC COATED PERFORATED METAL OR SLAT FLOOR
2	3/4" dia. x 2'-6" GALVANIZED PIPE - LIFTING HANDLES
4	3/8"x 1 1/2"x 10" STRAP IRON- LIFTING BAR SUPPORT
1	12"x12" PLEXIGLASS WINDOW- CALF DOOR FRONT
-	SUFFICIENT SCREWS, NAILS AND BOLTS FOR CONSTRUCTION
ELECTRICAL COMPONENTS	
2	SPST (SINGLE POLE SINGLE THROW) SWITCH
1	ELECTRICAL HANDY BOX
2	WEATHER PROOF ELECTRICAL BOXES WITH WEATHER PROOF SWITCH COVERS
1	DUPLEX OUTLET (125 VOLT - 15 AMPERE)
1	DUPLEX COVER
1	PORCELAIN LIGHT FIXTURE, 60 WATT BULB
1	NO. 14 UF CABLE
1	WIRE DUPLEX OUTLET TO ONE SWITCH FOR HEATER AND FAN
1	WIRE LIGHT TO SEPARATE SWITCH
1	1500 WATT ELE/WAIC HEATER WITH INTERNAL FAN AND THERMOSTAT
1	250 CFM FAN *

*CFM= CUBIC FEET OF AIR PER MINUTE

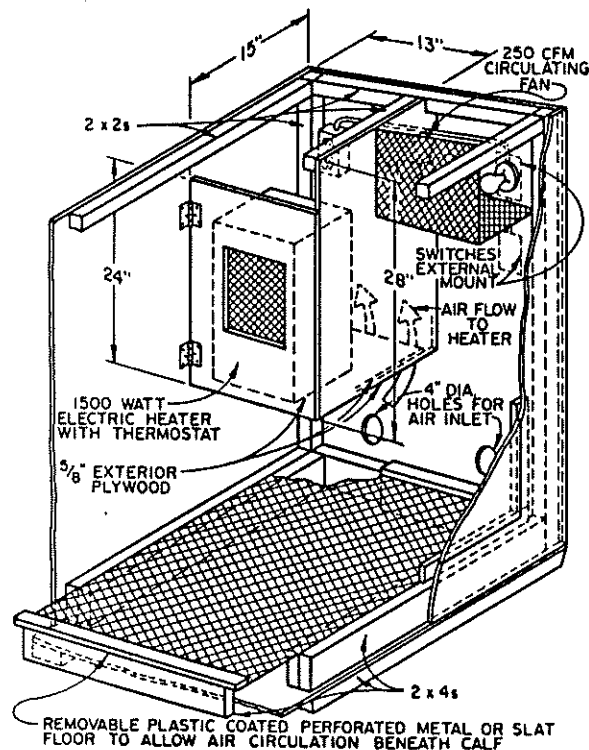

REMOVABLE PLASTIC COATED PERFORATED METAL OR SLAT FLOOR TO ALLOW AIR CIRCULATION BENEATH CALF

SCHEMATIC (no scale)

COOPERATIVE EXTENSION SERVICE
AGRICULTURE AND HOME ECONOMICS

AND
UNITED STATES DEPARTMENT OF AGRICULTURE COOPERATING

CALF WARMING BOX

MN '88 6397 SHEET | OF |