

COOPERATIVE EXTENSION SERVICE
 AGRICULTURE AND HOME ECONOMICS

AND
 UNITED STATES DEPARTMENT OF AGRICULTURE COOPERATING

CIRCULAR GRAIN BIN LAYOUTS

CAN. 86	6384	PAGE 1 OF 4
---------	------	-------------

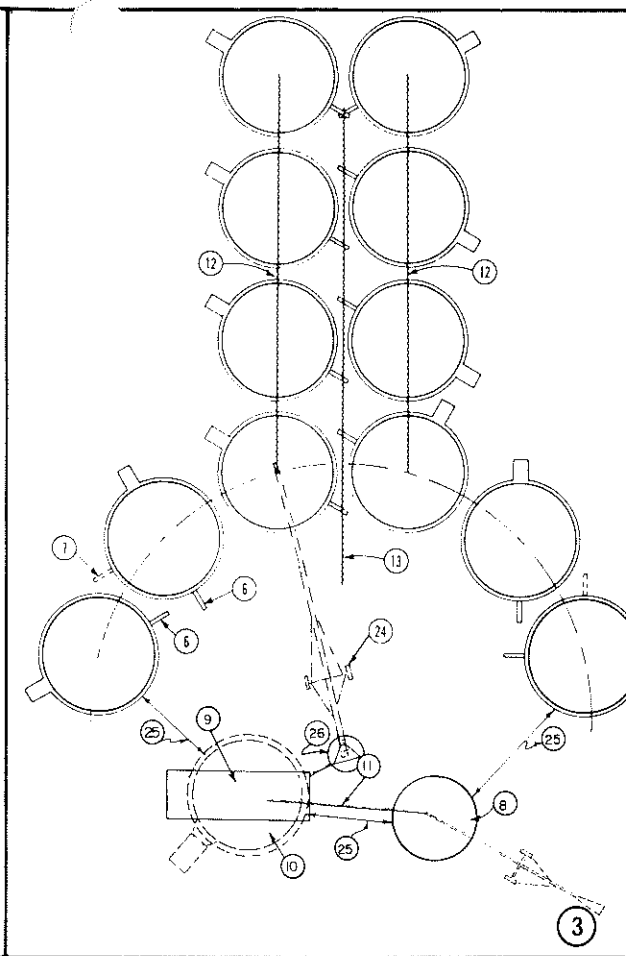
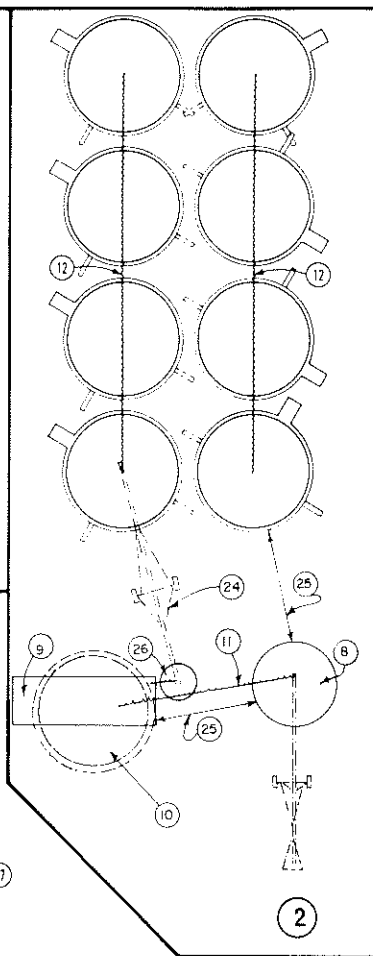
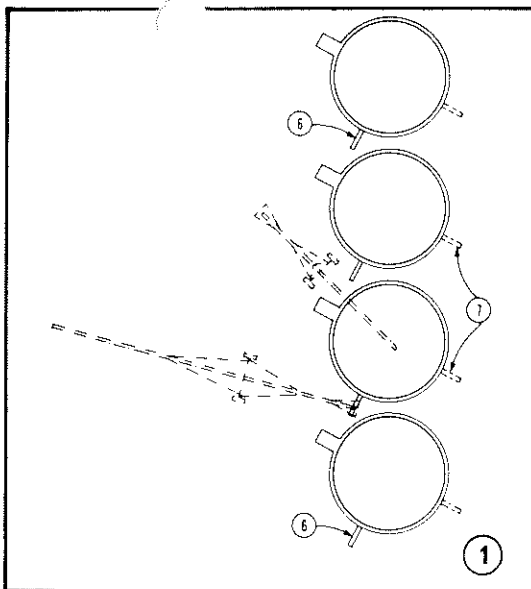

1. IN LINE STORAGE
2. DOUBLE-IN-LINE STORAGE, WITH CENTRALIZED HANDLING
3. EXPANSION TO SEMI-CIRCULAR ARRANGEMENT
4. SEMI-CIRCULAR ARRANGEMENT WITH BUCKET ELEVATOR (LEG)
5. SEMI-CIRCULAR GRAIN STORAGE SYSTEM DESIGN DATA
6. ALTERNATE DISCHARGE LOCATION OF BIN UNLOADING AUGER, USING CROSS-SHAPED AERATION DUCT
7. BIN UNLOADING AUGER LOCATION FOR CONVEYING TO CENTRAL HANDLING LOCATION
8. WET GRAIN SURGE HOPPER
9. GRAIN DRYER
10. GRAIN DRYER (ALTERNATE)
11. WET GRAIN UNLOADING AUGER
12. CONVEYOR INTO STORAGE
13. CONVEYOR OUT OF STORAGE
14. LEG
15. DRY GRAIN SURGE HOPPER (FOR CONTINUOUS FLOW DRYER)
16. DUMP PIT CROSS CONVEYER ON CENTERLINE OF DRIVEWAY
17. 2'-0" MIN. DISTANCE BETWEEN GRAIN BIN FOUNDATIONS, FOR GRAIN BINS WITH A WALL HEIGHT OVER 20'-0", ADD 1'-0" DISTANCE BETWEEN FOUNDATIONS FOR EVERY 10'-0" OF WALL HEIGHT
18. BIN DIAMETER ON CIRCLE
19. BIN DIAMETER WITHIN CIRCLE
20. CLEAR SPACE BETWEEN FOUNDATIONS
21. CIRCLE RADIUS
22. LEG HEIGHT AS INDICATED ON SHEET 3 OF 4
23. UNLOADING AUGER LENGTH
24. LOADING AUGER LENGTH
25. PROVIDE ADEQUATE CLEARANCE FOR ACCESS TO DRYER, BINS, AND ELEVATOR HOPPER
26. THE HOPPER OPENING SHOULD BE PROTECTED FROM RAIN

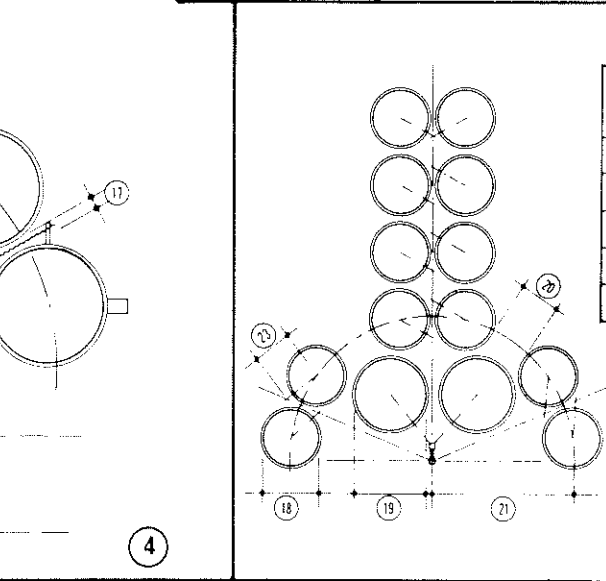
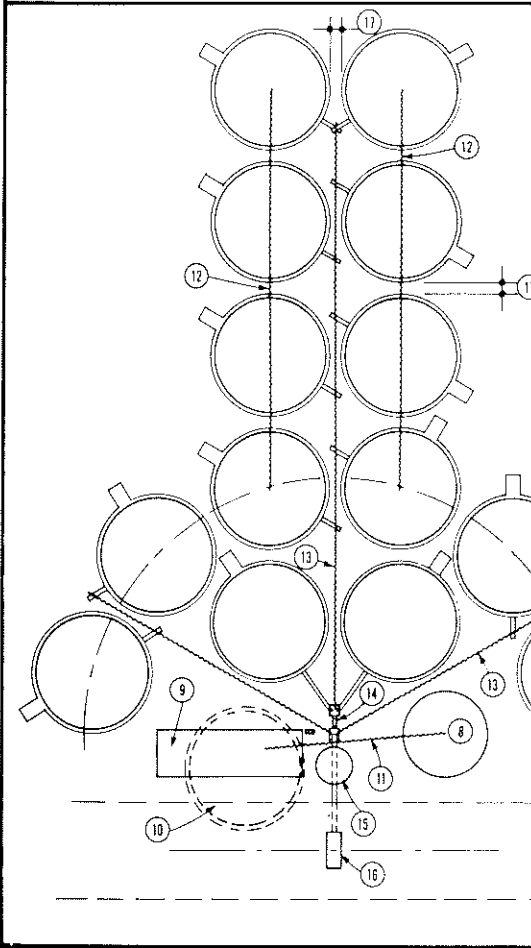

18	19	20	21	22	23	24
14'	19'	11'-0"	36'	50-60'	9'-7"	40-42'
16'	22'	12'	44'	60-75'	10'-9"	48-56'
19'	19'	2'	42'	60-70'	12'-7"	46-51'
19'	24'	11'	48'	65-75'	12'-7"	52-56'
22'	22'	2'	48'	65-85'	14'-6"	54-67'

COOPERATIVE EXTENSION SERVICE
 AGRICULTURE AND HOME ECONOMICS

UNITED STATES DEPARTMENT OF AGRICULTURE

CIRCULAR GRAIN BIN LAYOUTS

CAN. 86 6384 2 4

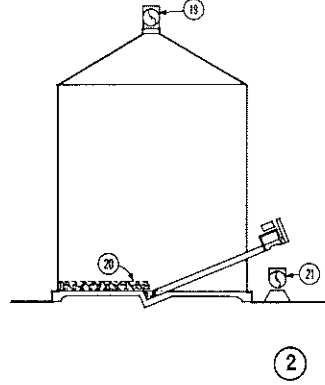
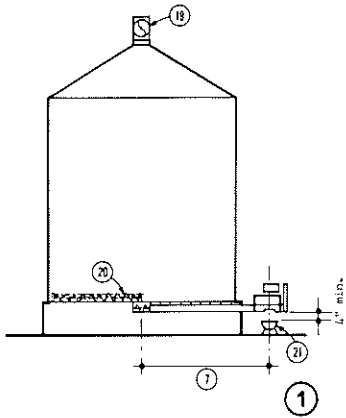

MATCHING LEG CAPACITY TO OTHER GRAIN HANDLING EQUIPMENT SIZES

	Length of Hopper	Equipment Size		Power
		LEG CAPACITY PER FT	CONVEYOR	
18		8-12"	12"	
19		8-12"	12"	
20		6"	8"	
21		8-10"	10-12"	
* 22		6-8"	8"	
* 23		6"	8"	
* 24		6"x5"	6"x5"	
25		6"	8"	
26		6"	8"	

* see 19, 18, 17, sheet 4.

1. UNDERFLOOR BIN UNLOADING .
2. INCLINED AUGER BIN UNLOADING SYSTEM
3. GRAIN HANDLING EQUIPMENT DATA
4. DUMP PIT CROSS CONVEYER AND HORIZONTAL AUGER TO LEG
5. DUMP PIT AND INCLINED CROSS CONVEYER TO LEG
6. SWING-AWAY HOPPER TRUCK DUMP AND INCLINED AUGER TO LEG
7. UNLOADING AUGER LENGTH (SEE 23, SHEET 2)
8. WET GRAIN HOLDING BIN
9. SELF CLEANING DEAD END
10. DISTRIBUTOR ACCESS SCAFFOLD
11. TWO-WAY VALVE TO DISTRIBUTOR AND WET GRAIN HOLDING BIN
12. 16'-0" MIN. DRIVEWAY WIDTH
13. 4'-0" MIN. OR AS REQUIRED BY MANUFACTURE'S SPECIFICATIONS
14. RETAINING WALLS AS REQUIRED, TIE BOTH SIDES TOGETHER WITH 3/4" DIA. RODS @ 4'-0" O.C. 1'-0" BELOW SURFACE

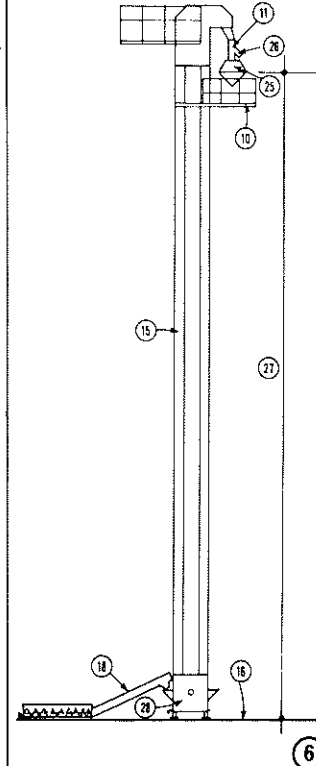
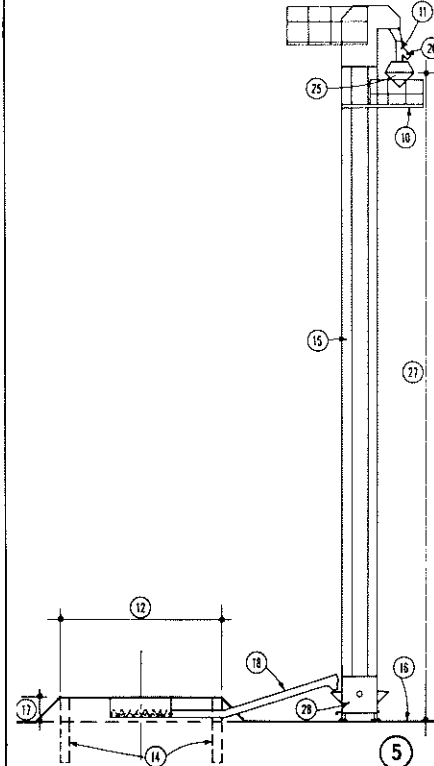
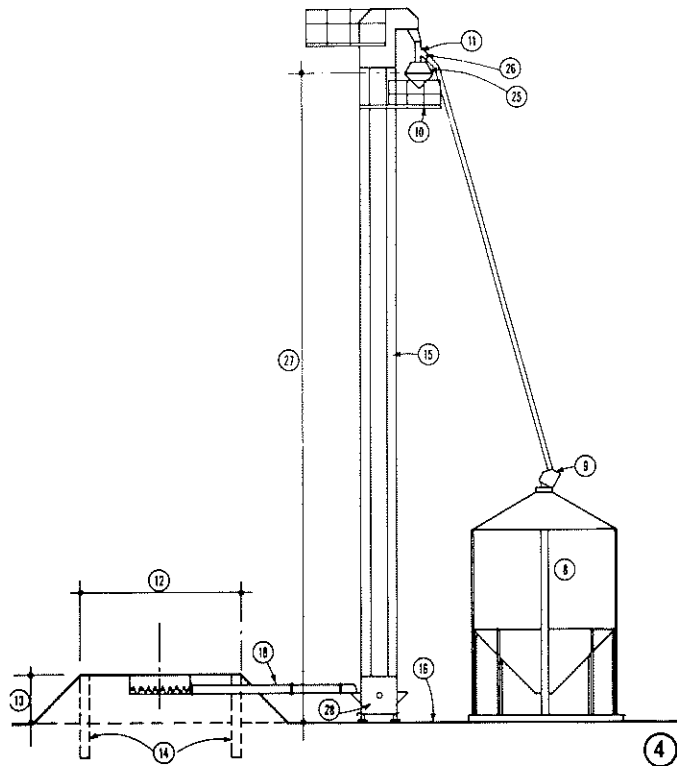

15. LEG
16. GRADE LEVEL
17. 2'-0" MIN. OR AS REQUIRED BY MANUFACTURE'S SPECIFICATIONS
18. DUMP PIT CROSS CONVEYOR
19. CONVEYOR INTO STORAGE
20. SWEEP AND UNLOADING AUGER
21. CONVEYOR OUT OF STORAGE
22. WET BIN UNLOADING AUGER
23. DRYER UNLOADING AUGER
24. DRYER UNLOADING LEG (CUPS)
25. DISTRIBUTOR-10 HOLE, 45°
26. SPOUTS
27. LEG HEIGHT (SEE 22, SHEET 2)
28. ELEVATOR BOOT ON LEGS, SLIDE GATE TO CLEAN OUT UNDER

NOTES:

RECOMMENDED LEG OPTIONS INCLUDE

- PVC BELTING
- SPLIT HEAD COVER
- 3' INSPECTION HATCH ON UP SIDE TRUNKING ABOVE BOOT

MIN. SPOUT SLOPES RECOMMENDED

- 40 DRY GRAIN
- 55 WET GRAIN
- FLOW RETARDERS ON LONG SPOUTS WHERE BEANS OR PEAS ARE TO BE HANDLED

COOPERATIVE EXTENSION SERVICE
AGRICULTURE AND HOME ECONOMICS

AND
UNITED STATES DEPARTMENT OF AGRICULTURE COOPERATING

CIRCULAR GRAIN BIN LAYOUTS

CAN. 86

6384

SHEET 3 OF 4

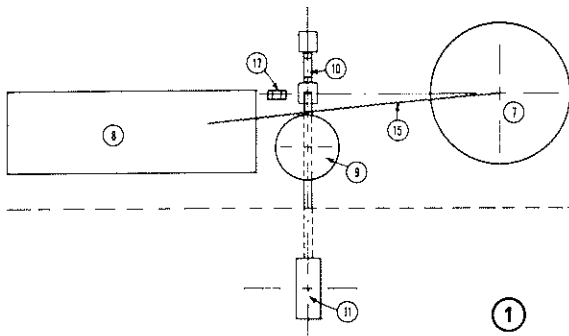

1

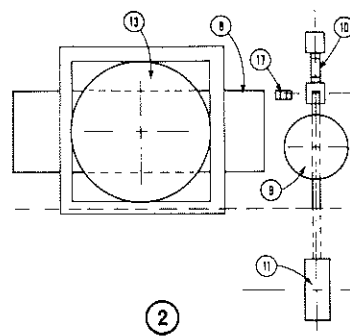

2

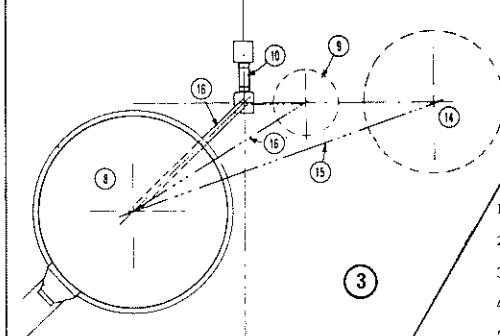

3

1. LAYOUT OF GRAIN DRYING SYSTEM
2. LAYOUT OF GRAIN DRYING SYSTEM WITH OVERHEAD BIN
3. LAYOUT OF GRAIN DRYING SYSTEM
4. PROFILE OF GRAIN DRYING SYSTEM (SEE 1, THIS SHEET)
5. PROFILE OF GRAIN DRYING SYSTEM (SEE 2, THIS SHEET)
6. PROFILE OF GRAIN DRYING SYSTEM (SEE 3, THIS SHEET)
7. WET GRAIN HOLDING BIN
8. GRAIN DRYER (BATCH OR CONTINUOUS FLOW)
9. DRY GRAIN SURGE HOPPER (OPTIONAL FOR BATCH DRYER)
10. LEG
11. DUMP PIT AND CROSS CONVEYER TO LEG
12. 6'-0" OR AS REQUIRED TO GAIN ACCESS TO LEG INSPECTION HATCH
13. WET GRAIN HOLDING BIN, TEMPORARY SEED OR BULK FERTILIZER BIN, QUICK LOAD-OFF BIN. HEIGHT TO AND LOCATION OF DISCHARGE DEPENDENT UPON DRYER AND DRIVEWAY HEIGHT SELECTED
14. OPTIONAL WET GRAIN HOLDING BIN
15. WET BIN UNLOADING AUGER
16. DRYER UNLOADING AUGER (SEE 23, SHEET 3)
17. DRYER UNLOADING LEG (CUPS)

NOTES:

- DRY GRAIN SURGE HOPPER AND DRY GRAIN LEG ARE REQUIRED FOR CONTINUOUS FLOW DRYERS ONLY.
- DRYING RATE SHOULD BE AT LEAST ONE-HALF OF COMBINING RATE. THEN ONE-HALF DRY COMBINING VOLUME IS THE MINIMUM VOLUME OF WET GRAIN SURGE BIN REQUIRED.
- WET GRAIN SURGE HOPPER (14) IS OPTIONAL FOR BIN DRYER.

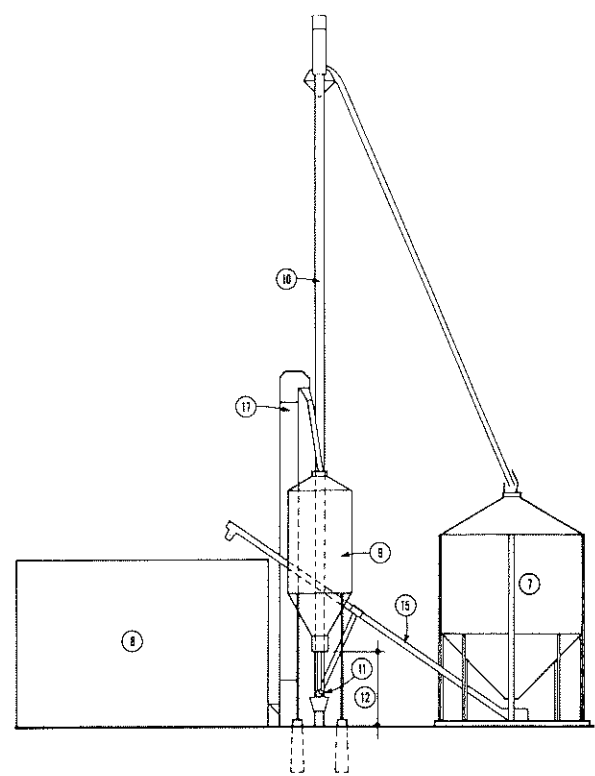

4

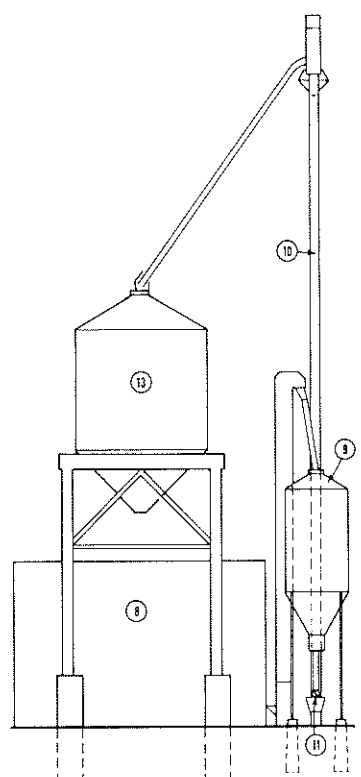

5

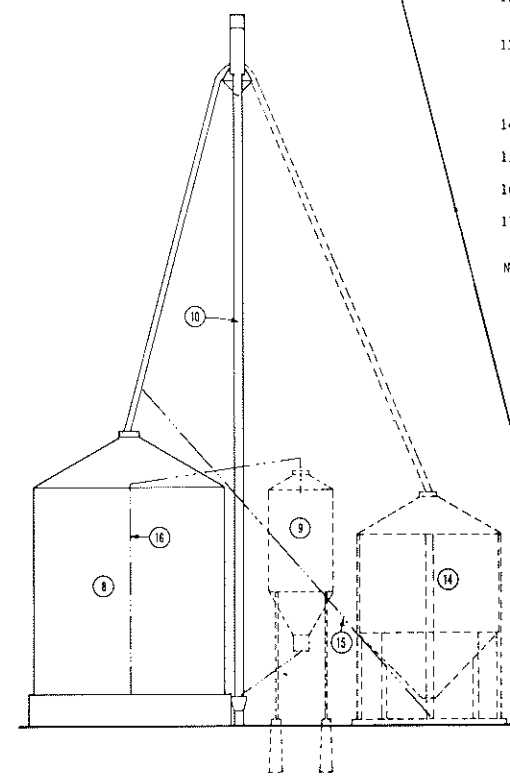

6

COOPERATIVE EXTENSION SERVICE
AGRICULTURE AND HOME ECONOMICS

AND
UNITED STATES DEPARTMENT OF AGRICULTURE COOPERATING

CIRCULAR GRAIN BIN LAYOUTS