

NOTES:

LOFT FLOOR SHOWN AS 8' WIDE - MAY BE EXTENDED TO COVER EQUIPMENT AREA.

LOFT ACCESSED BY LADDER IN SHOP.

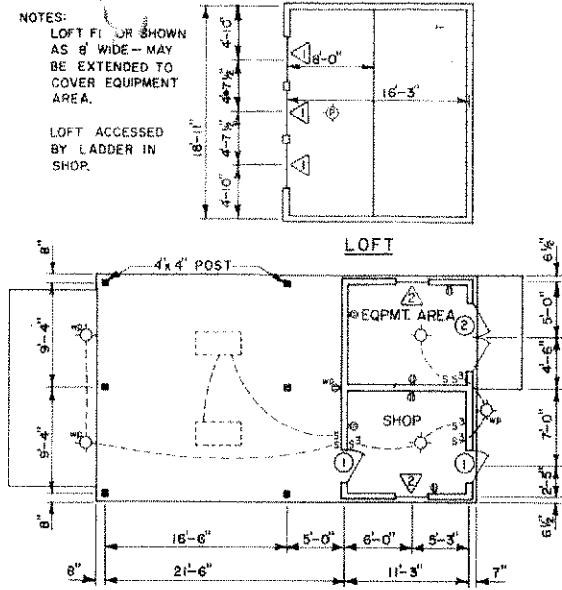

FLOOR PLAN

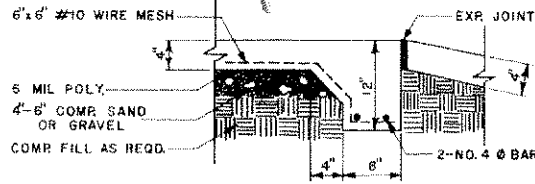

SECTION A

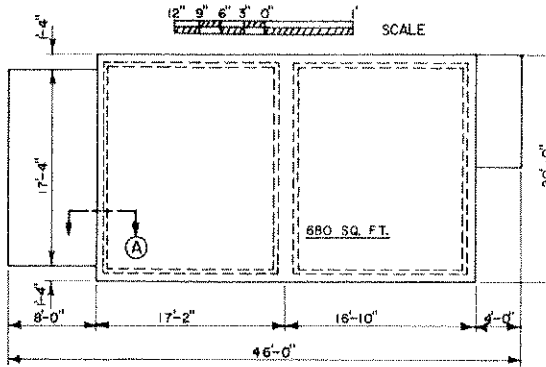

FOUNDATION PLAN

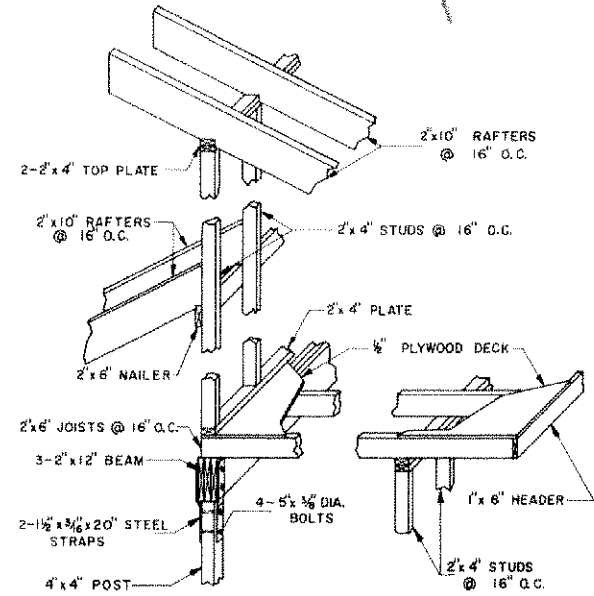

LOFT DETAIL

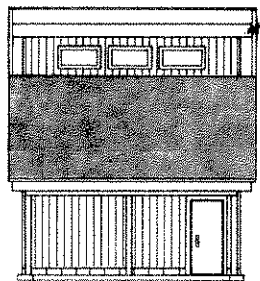

FRONT ELEVATION

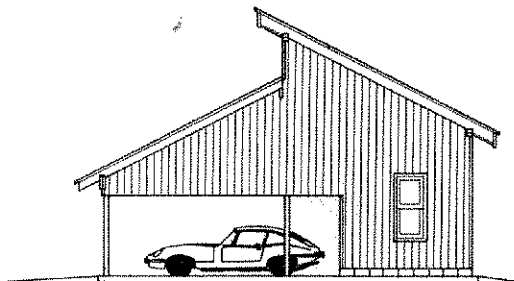

RIGHT ELEVATION

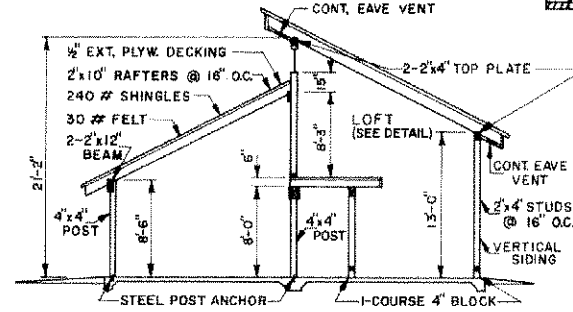

CROSS SECTION

DOOR SCHEDULE	
1	STEEL CLAD w/ INSUL. CORE 3'-0" x 6'-6"
2	" " " " " " " " 6'-0" x 6'-6"

NOTES:
 ALL FILL SOIL SHALL BE COMPACTED TO 95% STANDARD PROCTER.
 ALL FOUNDATION SOILS SHALL BE THOROUGHLY TREATED FOR TERMITE PROTECTION.
 STRUCTURE DESIGNED FOR SNOW LOAD OF 25 LB./SQ. FT.

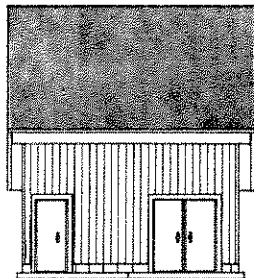

REAR ELEVATION

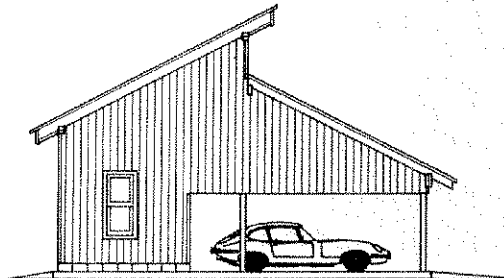

LEFT ELEVATION

WINDOW SCHEDULE	
AWNING WINDOW	4'-0" x 2'-0"
DOUBLE HUNG WINDOW	3'-0" x 6'-0"

ELECTRICAL KEY	
S	SINGLE POLE SWITCH
S3	THREE-WAY SWITCH
⊕	DUPLEX CONVENIENCE OUTLET
⊕ _{wp}	WEATHERPROOF CONVENIENCE OUTLET
⊕ _{ce}	CEILING OUTLET
⊕ _{wp}	WEATHERPROOF WALL OUTLET
⊕ _{pl}	PULL CHAIN LIGHT

UNLESS OTHERWISE NOTED

COOPERATIVE EXTENSION WORK IN AGRICULTURE AND HOME ECONOMICS

AND UNITED STATES DEPARTMENT OF AGRICULTURE COOPERATING

CONTEMPORARY CARPORT, SHOP AND STORAGE

MS. '81 EX. 6345 SHEET 1 OF 1