

FEED CART

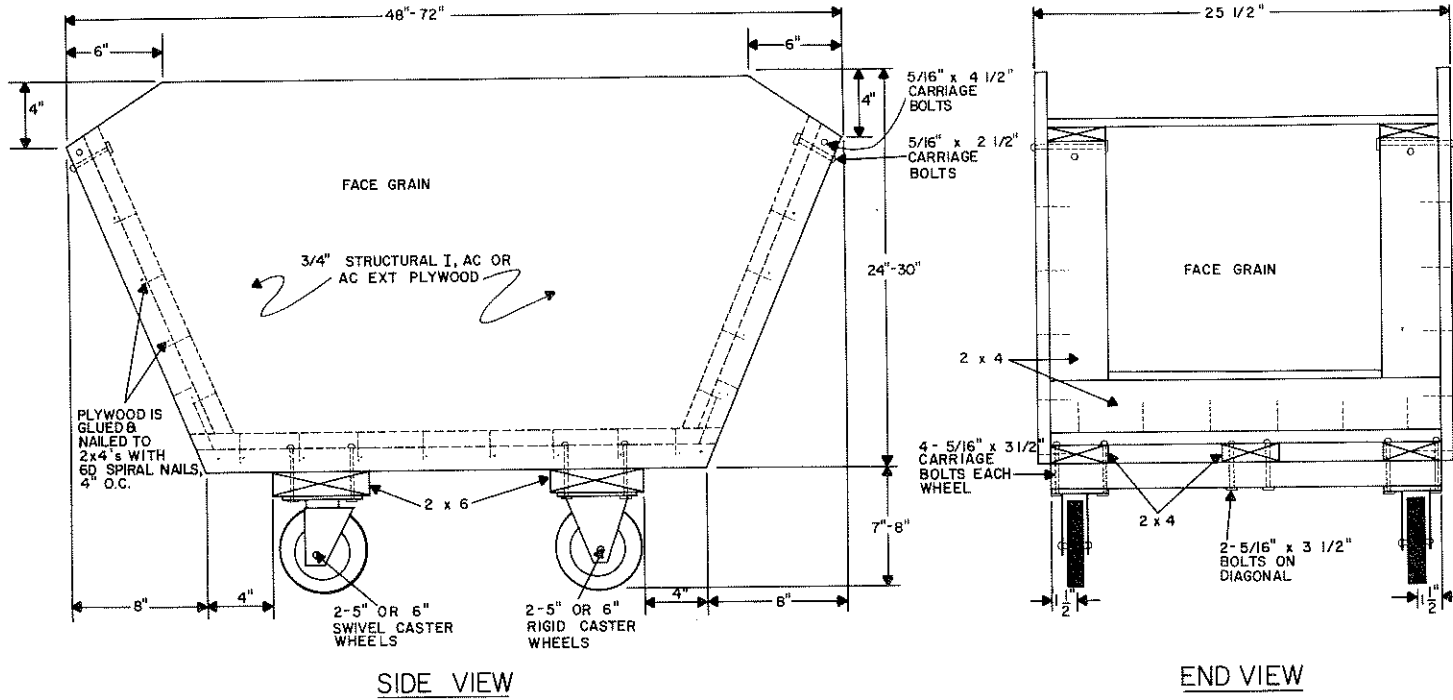

BILL OF MATERIALS LUMBER AND OTHER CONSTRUCTION MATERIALS:

NUMBER OF PIECES	DIMENSION	GRADE AND KIND	USE
2 (48" CART)	3/4" x 4' x 8'	STRUCTURAL I, AC OR AC EXTERIOR	SIDES, ENDS, BOTTOMS
3 (72" CART)	" " " "	" " " "	" " " "
2 (48" CART)	2 x 4 x 10'	CONSTRUCTION OR NO. 1 FIR	FRAMING
1 (72" CART)	2 x 4 x 12'	" " " "	"
1 (72" CART)	2 x 4 x 14'	" " " "	"
1	2 x 6 x 4'	" " " "	"

FASTNERS AND OTHER HARDWARE:

AMOUNT	SIZE	ITEM
2	5" OR 6" DIAMETER, 400 LBS CAPACITY SWIVEL CASTER	WHEELS
2	5" OR 6" DIAMETER, 400 LBS CAPACITY RIGID CASTER	WHEELS
20	5/16" x 3-1/2", CARRIAGE, WITH WASHERS	BOLTS
4	5/16" x 4-1/2" " " " "	"
4	5/16" x 2-1/2" " " " "	"
1-1/2 LB	6d SPIRAL RESORCINOL (WATERPROOF)	NAILS
1/2 PT	"	GLUE

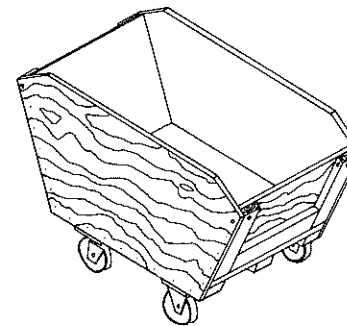

12" 0' 2' 4' 7'
SCALE

COOPERATIVE EXTENSION WORK IN
AGRICULTURE AND HOME ECONOMICS

UNITED STATES DEPARTMENT OF AGRICULTURE COOPERATING

FEED CART

NY 82 EX. 6343 SHEET 1 OF 1