

WINCH HEIGHT MUST BE ADJUSTED SO THAT CABLE IS PARALLEL WITH BEARING PLATE BENEATH CENTER OF PULL-ON BEAM SHEAVES

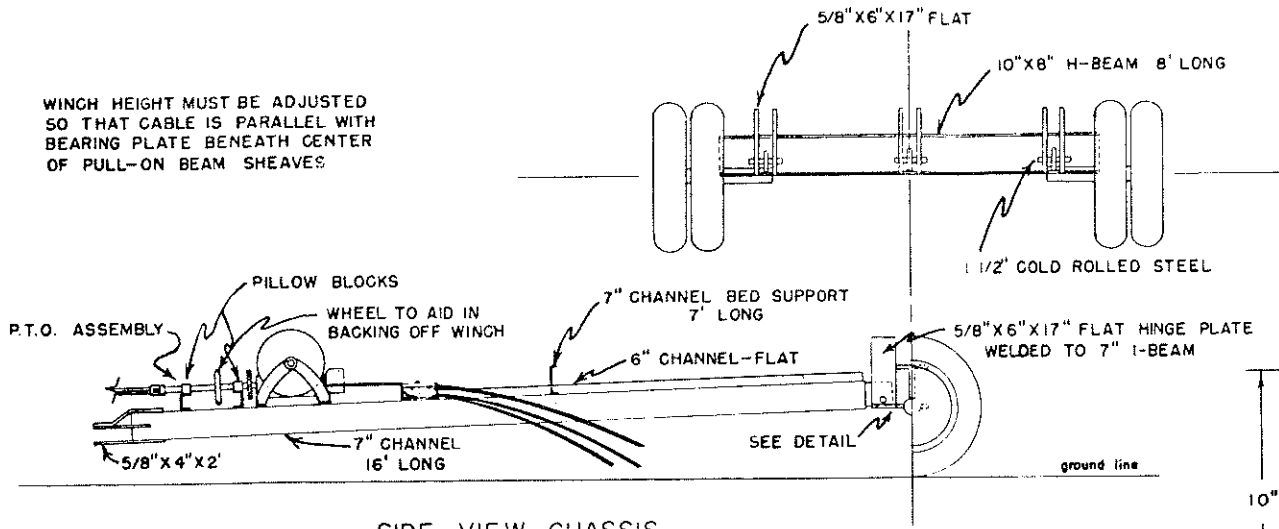

SIDE VIEW CHASSIS

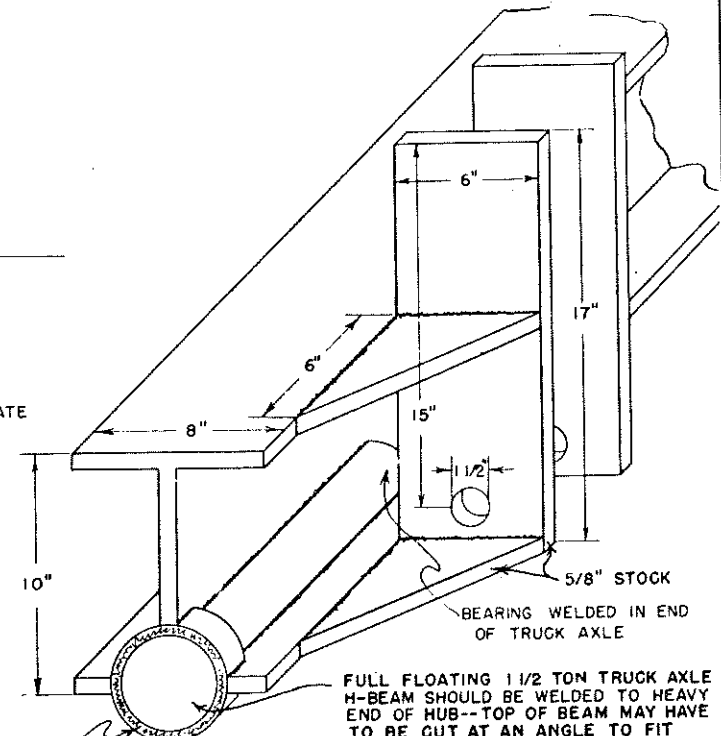

PIN ASSEMBLY DETAIL

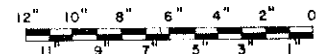

THIS SLED DESIGNED TO HANDLE 4 TO 6 TON ROUND HAY STACKS. STACKS ARE BUILT 16" IN DIAMETER AND APPROX. 20' HIGH.

BASED ON: SOUTH DAKOTA STATE UNIV. PLAN NO. 548

POWER TAKE-OFF DRIVEN WINCH WELDED OR BOLTED ON TO FRAME (MINIMUM OF 12,000 LBS. SAFE WORKING LOAD)

SMALL WHEEL TO AID IN BACKING OFF WINCH

P.T.O. MUST BE SHIELDED

PULL-ON BEAM 8" I-BEAM 14' LONG (MAY BE 13' LONG)

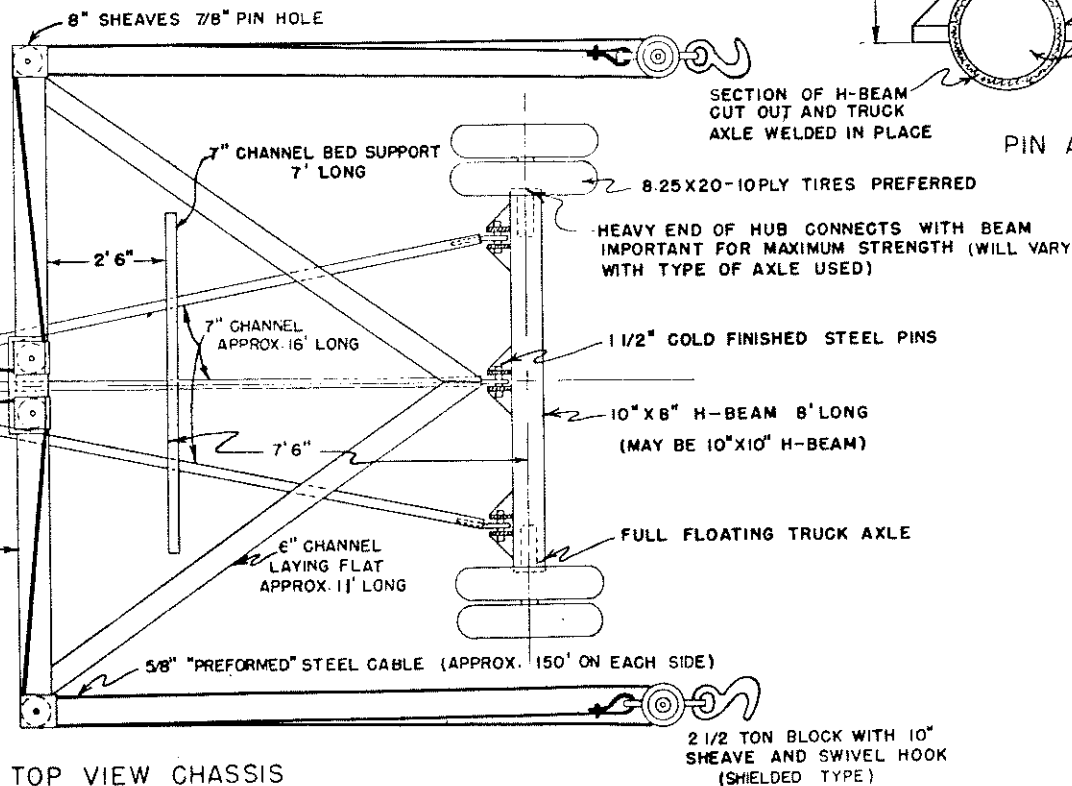

TOP VIEW CHASSIS

2 1/2 TON BLOCK WITH 10" SHEAVE AND SWIVEL HOOK (SHIELDED TYPE)

COOPERATIVE EXTENSION WORK IN AGRICULTURE AND HOME ECONOMICS

AND UNITED STATES DEPARTMENT OF AGRICULTURE COOPERATING

TILTING FLATBED HAYSLED

AZ 8 S.D. '76	6 2 5 4	SHEET 1 OF 4
---------------	---------	--------------

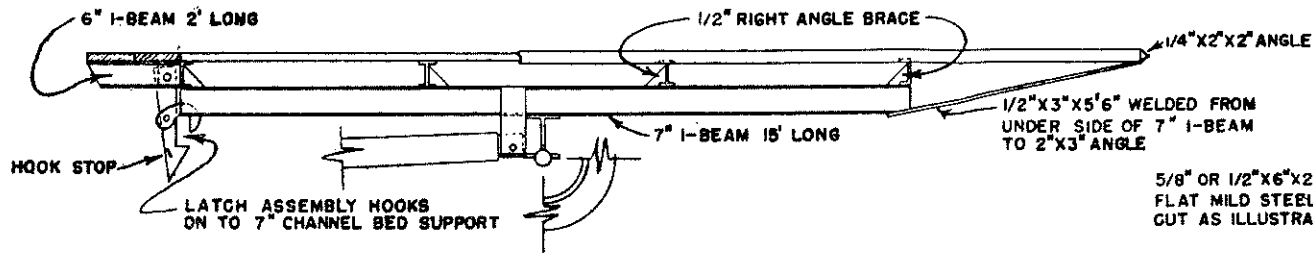

SIDE VIEW BED STRUCTURE

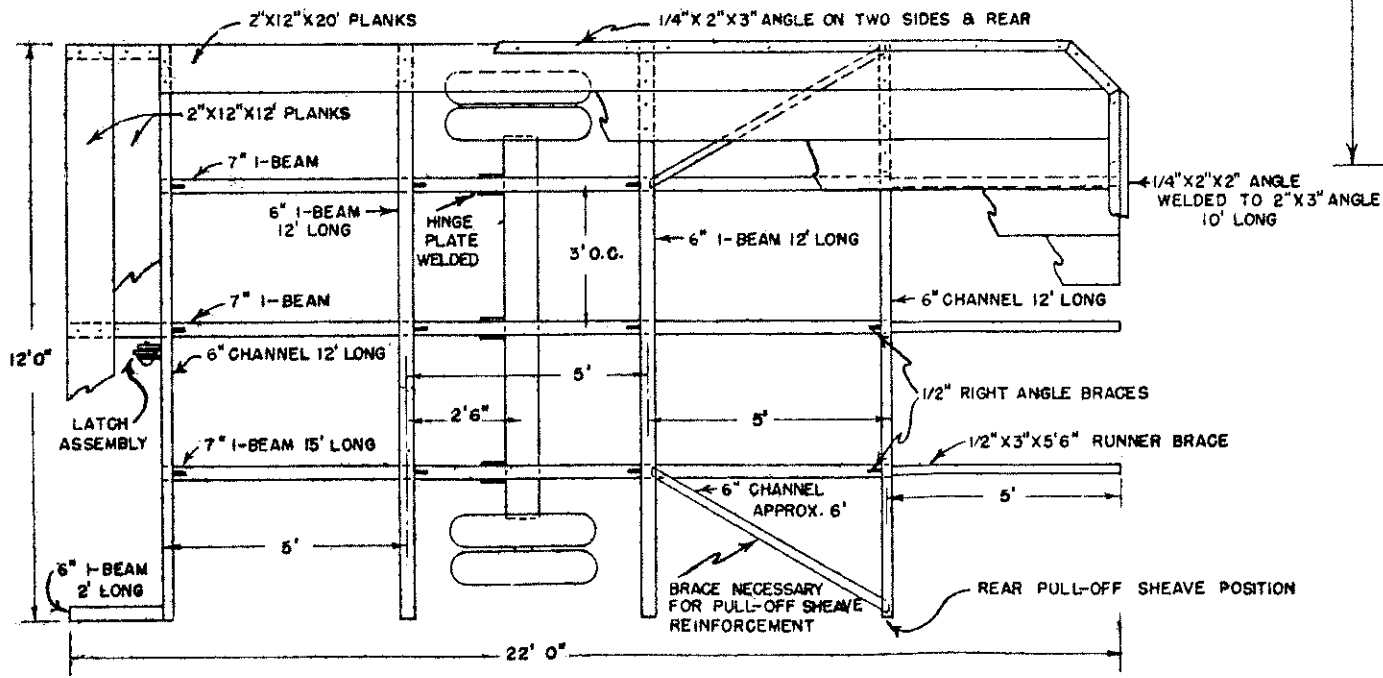

TOP VIEW BED STRUCTURE

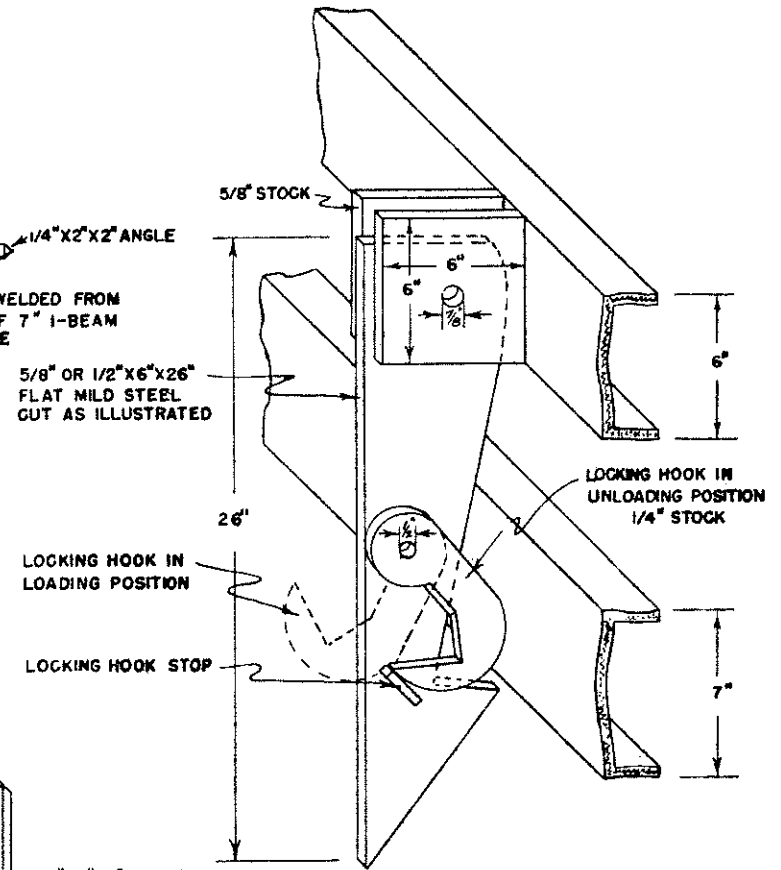
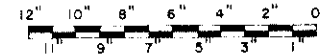

TABLE HOOK ASSEMBLY



SCALE: 1/2"=1'-0" UNLESS OTHERWISE NOTED.

COOPERATIVE EXTENSION WORK IN
AGRICULTURE AND HOME ECONOMICS

AND
UNITED STATES DEPARTMENT OF AGRICULTURE COOPERATING

TILTING FLATBED HAYSLER

AZ & S.D. '76 6 2 5 4 SHEET 2 OF 4

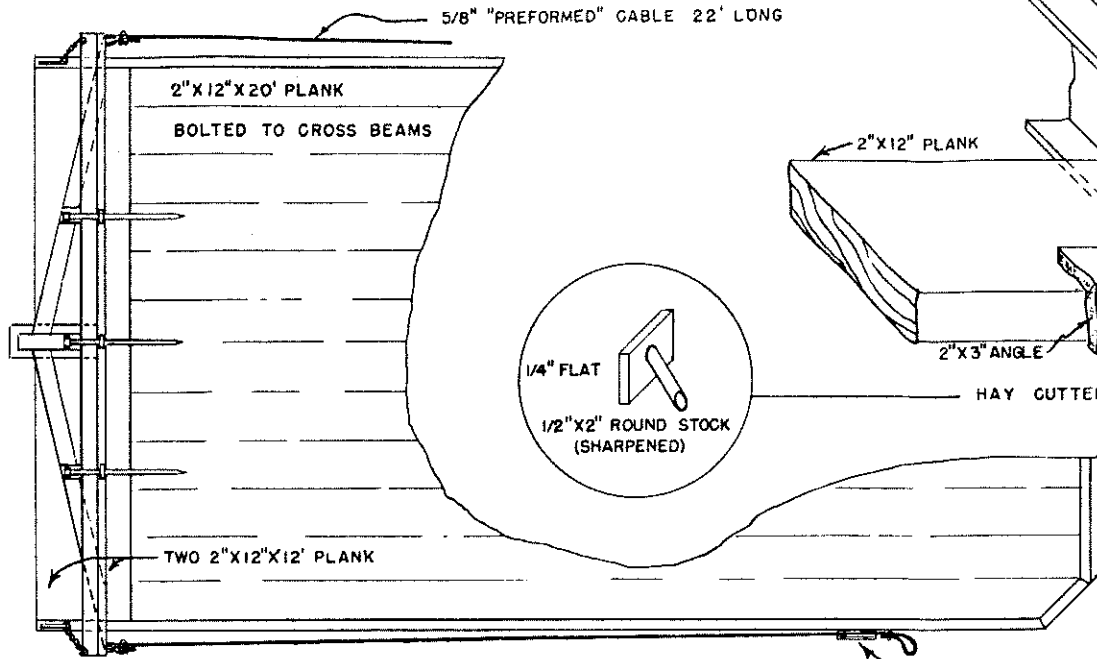

TOP VIEW TABLE

SCALE: 1/2"=1'
12" 6" 0" 2"

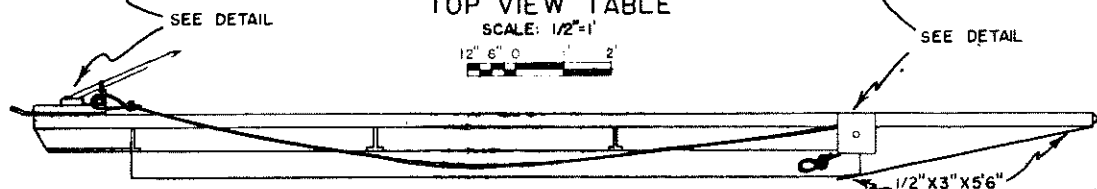

SIDE VIEW TABLE

SCALE: 1/2"=1'
12" 6" 0" 1" 2"

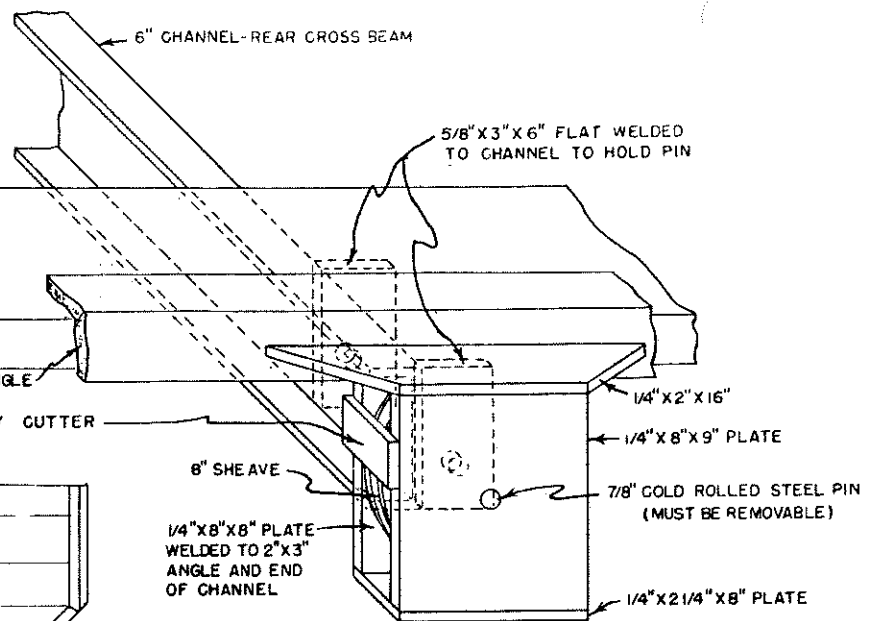

REAR PULL-OFF SHEAVE DETAIL

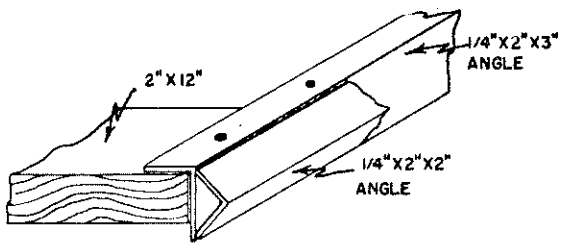

END EDGE DETAIL

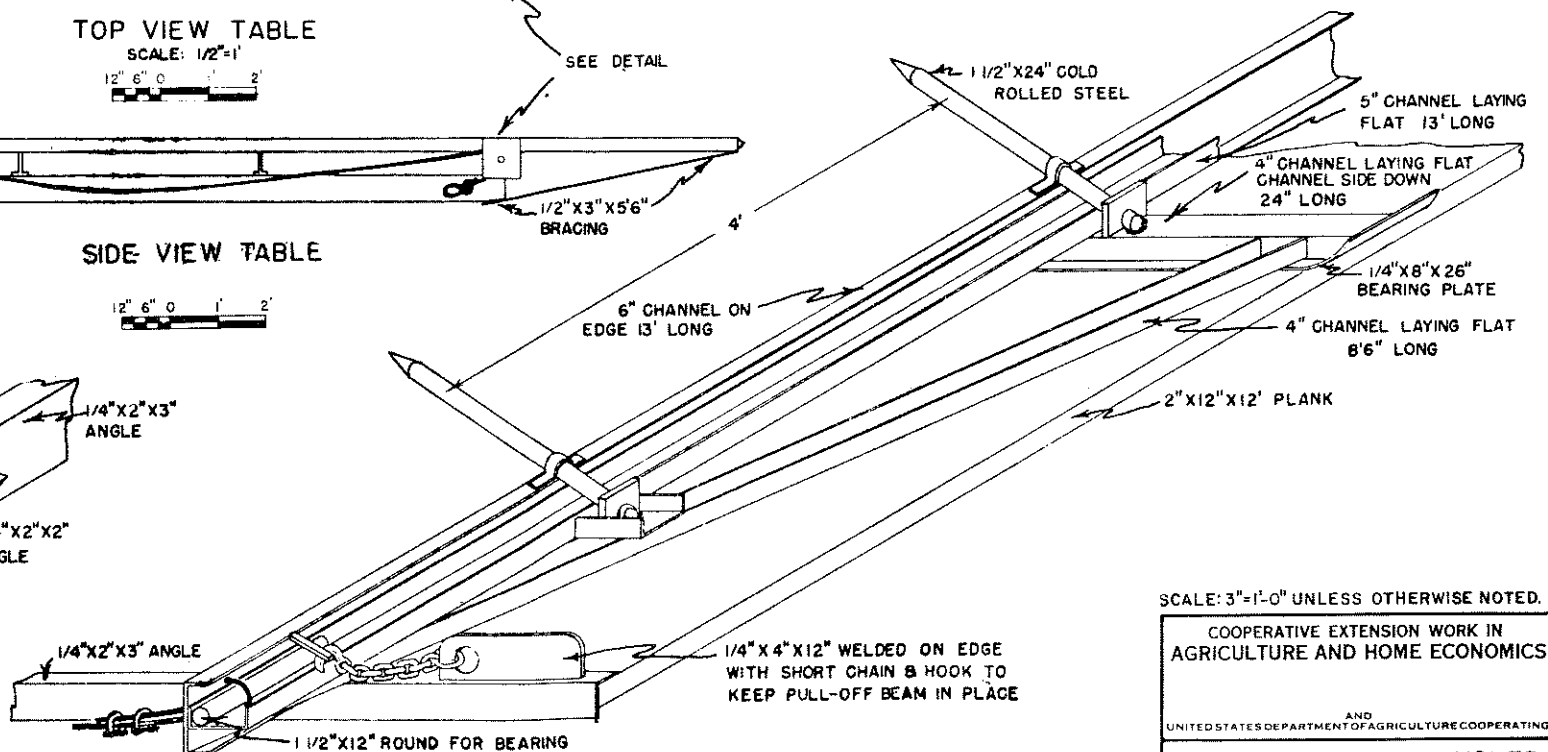

PULL-OFF BEAM DETAIL

SCALE: 3"=1'-0" UNLESS OTHERWISE NOTED.
12" 9" 6" 3" 0"

SCALE: 3"=1'-0" UNLESS OTHERWISE NOTED.

COOPERATIVE EXTENSION WORK IN AGRICULTURE AND HOME ECONOMICS

AND UNITED STATES DEPARTMENT OF AGRICULTURE COOPERATING

TILTING FLATBED HAYSLED

AZ 8 S.D. '76 6 2 5 4 SHEET 3 OF 4

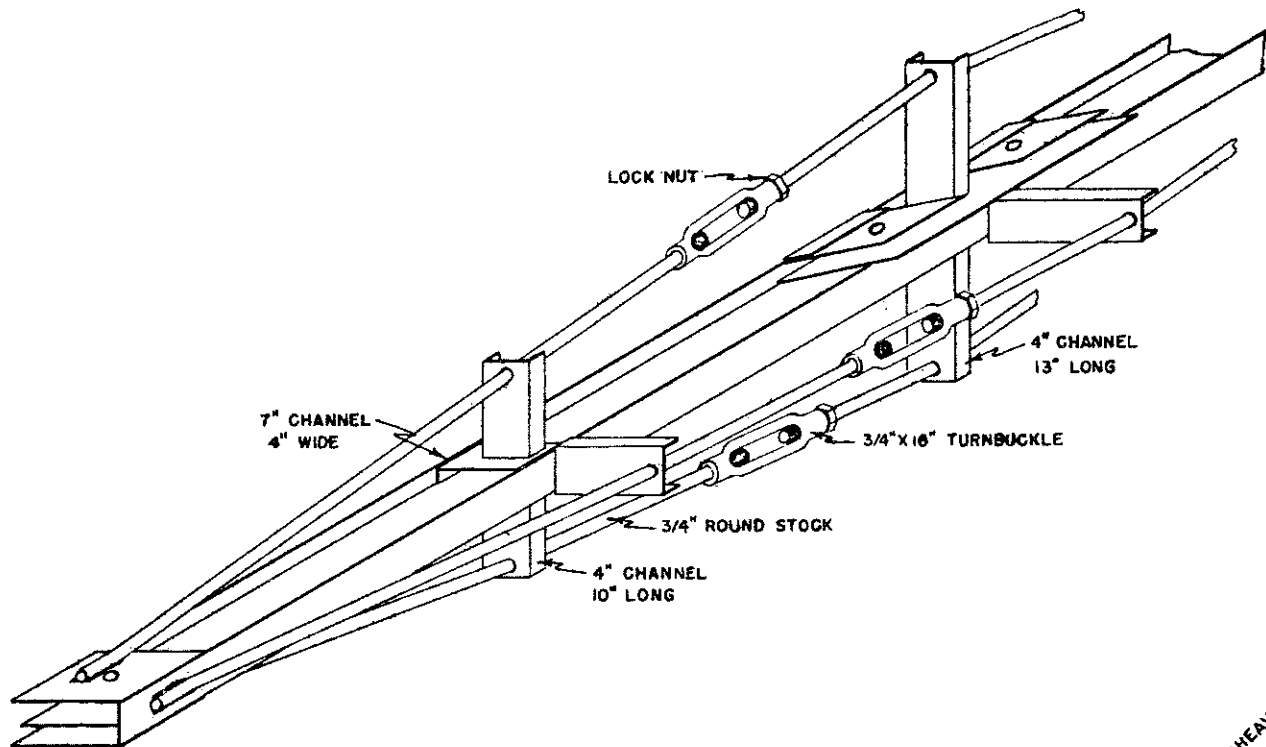

PULL-ON BEAM BRACING
SCALE: 1 1/2" = 1'

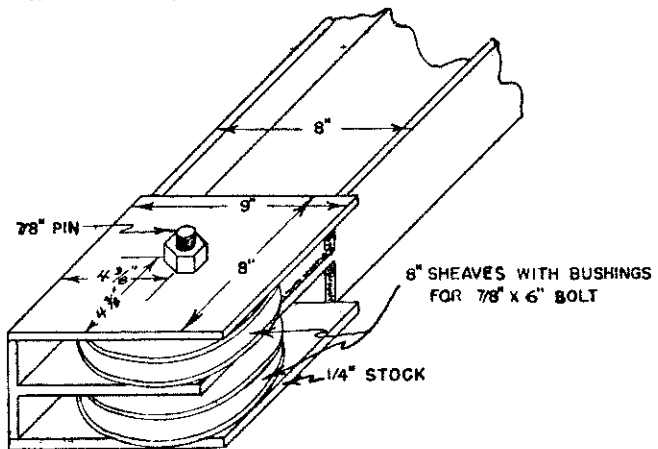
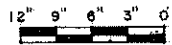

END OF PULL-ON BEAM

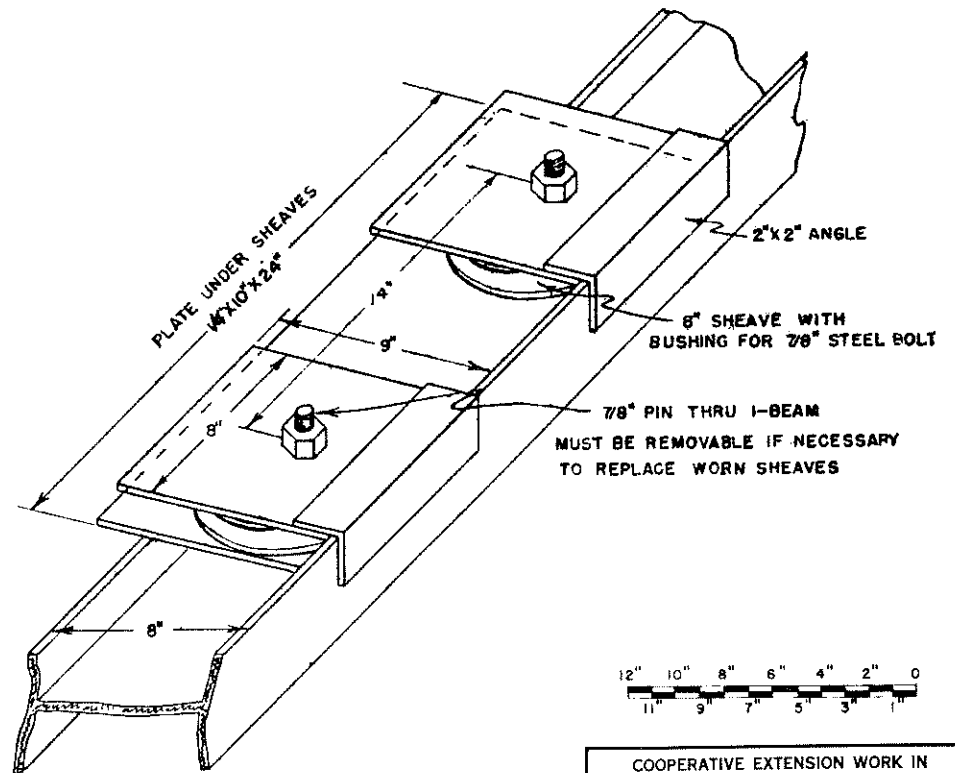

CENTER OF PULL-ON BEAM

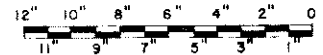

COOPERATIVE EXTENSION WORK IN
AGRICULTURE AND HOME ECONOMICS

AND
UNITED STATES DEPARTMENT OF AGRICULTURE COOPERATING

TILTING FLATBED HAYSLED

AZ 8 S.D. '76 6 2 5 4 SHEET 4 OF 4