

7'-0" x 4'-0" SCREEN, 3'-0" FROM FINISH FLOOR.

NOTE:
CONCRETE PAVED & DRAINED.
LIVESTOCK PENS AS NEEDED.

PLAN

KEY	
NO.	DESCRIPTION
1	LAVATORY AND STERILIZER
2	KNOCKERS PLATFORM
3	KNOCKING BOX
4	DRY LANDING AREA
5	CATTLE BLEEDING AREA
6	CATTLE CRADLE
7	CATTLE HEAD FLUSHING BOOTH
8	CATTLE HEAD INSPECTION TRUCK
9	CARCASS WASHING AND SHROUDING
10	CATTLE SPREADER
11	SAW STERILIZER
12	SMOKENHOUSE
13	CUTTING TABLE
14	VISCERA TRUCK
15	REVOLVING PEN DOOR

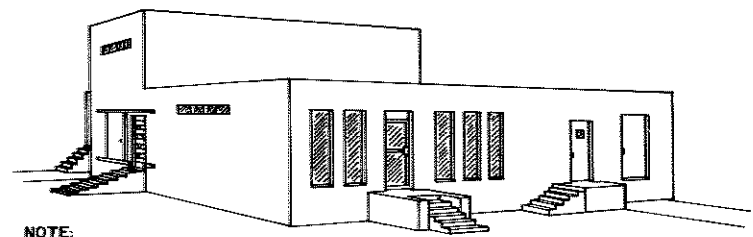

NOTE:
RAILING NOT SHOWN.
SEE EAST ELEVATION.

PERSPECTIVE

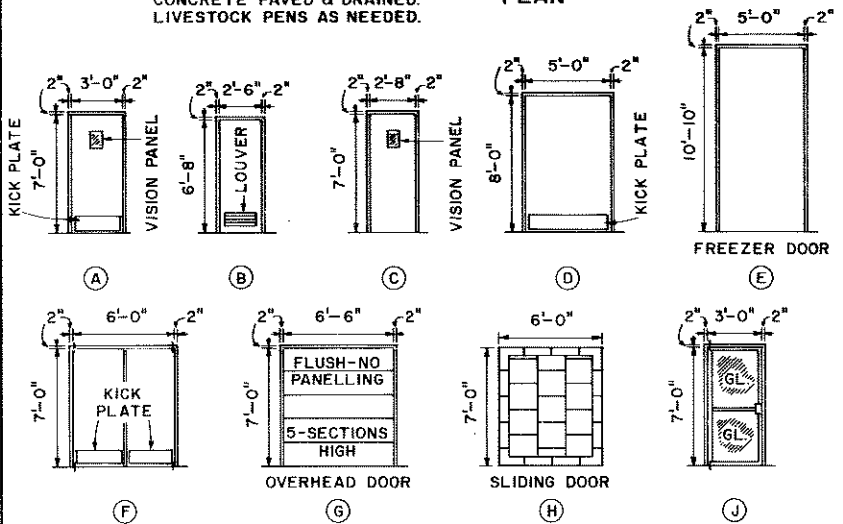

DOOR SCHEDULE

SCALE: 3/16" = 1'-0"
12' 0" 1' 2' 3' 4' 5' 6' 7' 8'

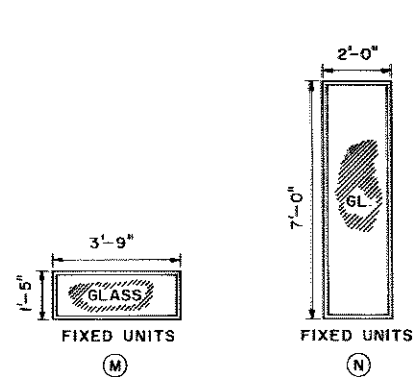

WINDOW SCHEDULE

SCALE: 3/8" = 1'-0"
12' 6" 0" 1' 2' 3'

NOTES:
THE PURPOSE OF THESE PLANS IS TO SERVE
AS A GUIDE ONLY.
FOR A PLANT TO BE ELIGIBLE FOR OFFICIAL
INSPECTION, DETAILED PLANS MUST BE
SUBMITTED TO YOUR LOCAL HEALTH &
BUILDING CODE AUTHORITIES, FOR APPROVAL
BEFORE CONSTRUCTION IS BEGUN.

COOPERATIVE EXTENSION WORK IN
AGRICULTURE AND HOME ECONOMICS

AND
UNITED STATES DEPARTMENT OF AGRICULTURE COOPERATING

MEAT PACKING PLANT

TEX	'75	6227	SHEET 1 OF 2
-----	-----	------	--------------

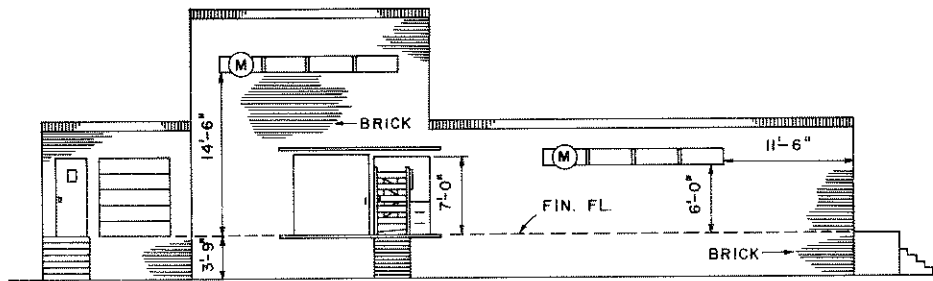

NORTH ELEVATION

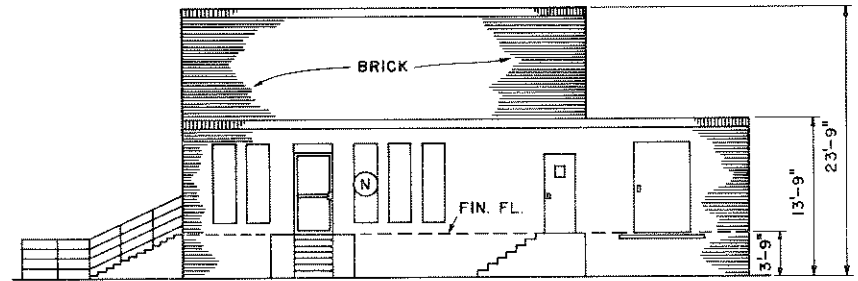

EAST ELEVATION

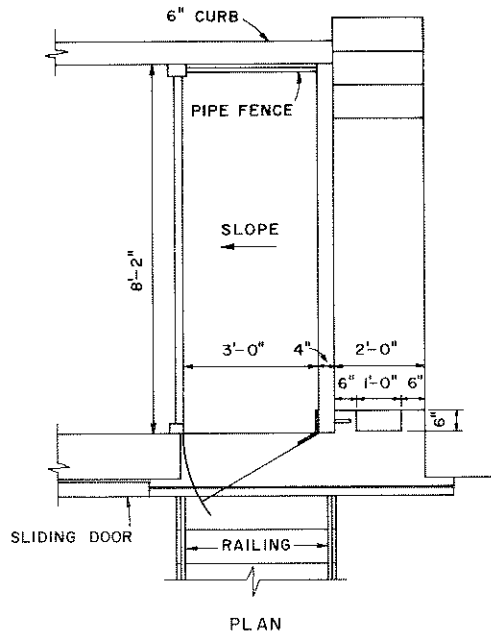

PLAN

KNOCKING PEN DETAILS

SCALE: $\frac{1}{2}'' = 1'-0''$
 12' 6" 0' 1' 2'

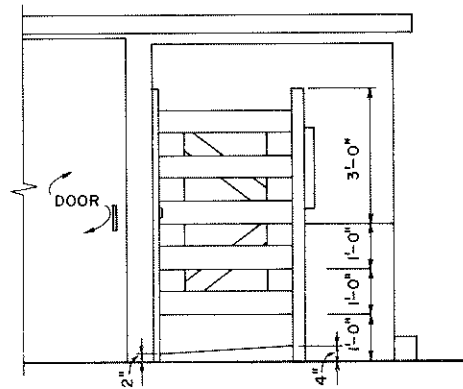

FRONT ELEVATION

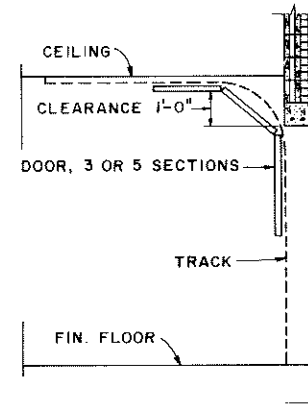

SECTION A-A

SCALE: $\frac{3}{8}'' = 1'-0''$
 12' 6" 0' 1' 2'

COOPERATIVE EXTENSION WORK IN
 AGRICULTURE AND HOME ECONOMICS

AND
 UNITED STATES DEPARTMENT OF AGRICULTURE COOPERATING

MEAT PACKING PLANT

TEX. '75 6227 SHEET 2 OF 2