

PERSPECTIVE

NOTE:
CURTAIN NOT SHOWN.
GUTTER & DOWNSPOUT
NOT SHOWN.

NOTES:
BOARD TYPE INSULATION TO BE
APPLIED TO RAFTERS BEFORE
PLACING CORRUGATED METAL
ROOFING.

METAL GUTTER AND DOWNSPOUT
ON SOUTH SIDE OF ROOF.

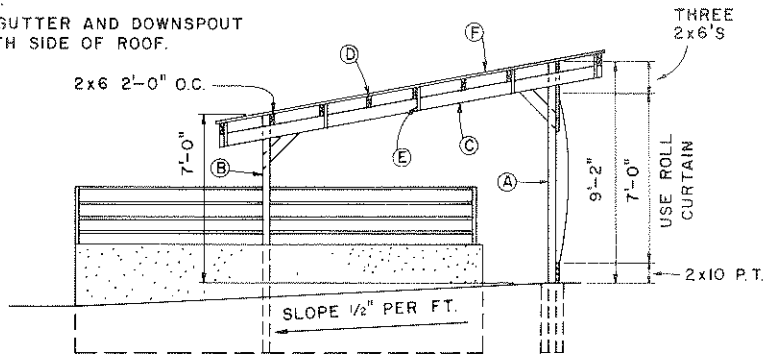

SIDE ELEVATION

NOTE:
FOOTINGS TO BEAR ON
FIRM BASE BELOW
FROST LINE.

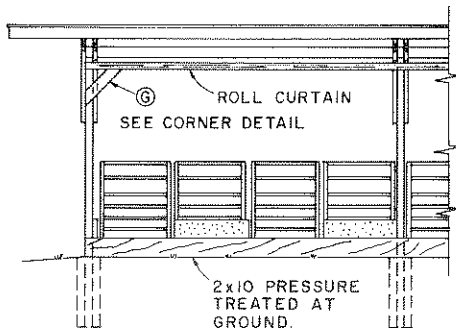

FRONT ELEVATION

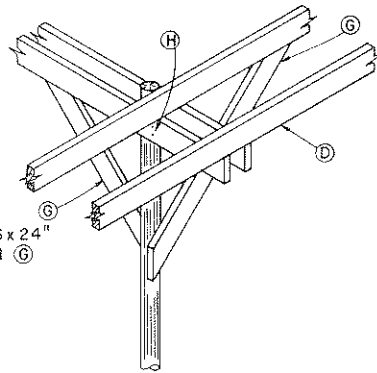

CORNER DETAIL
NOT TO SCALE

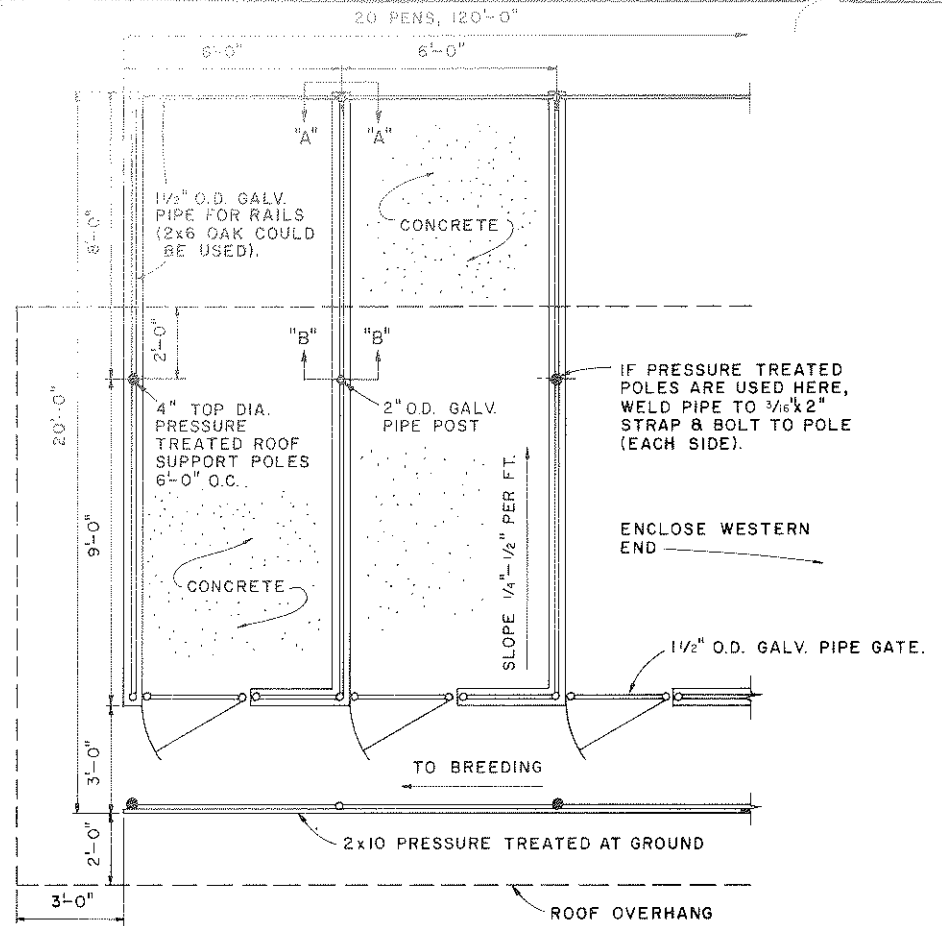

PLAN
SCALE: 3/8"=1'-0"

CUTTING LIST

- A 4" TOP x 12'-0" POLES PRESSURE TREATED.
- B 4" TOP x 10'-0" POLES PRESSURE TREATED.
- C 2x6 x 16'-0"
- D 2x6 x 16'-0" ON END BAYS
2x6 x 14'-0" ON INTERMEDIATE BAYS.
- E 2x2 x 12"
- F 16'-0" x 26" CORR. METAL.
- G 2x6 x 4'-0"
- H 1/2" x 9" BOLTS

SCALE: 1/2"=1'-0" UNLESS
OTHERWISE NOTED

COOPERATIVE EXTENSION WORK IN
AGRICULTURE AND HOME ECONOMICS

AND
UNITED STATES DEPARTMENT OF AGRICULTURE COOPERATING

HOG HOUSE FOR BOARS

MISS '75 6207 SHEET 1 OF 2

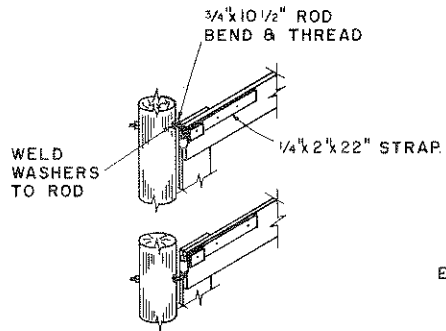

NOTE:
IF STEEL PIPE IS USED,
USE HEAVY STRAP WITH
3/4" DIA. L PIN WELDED
TO POST.

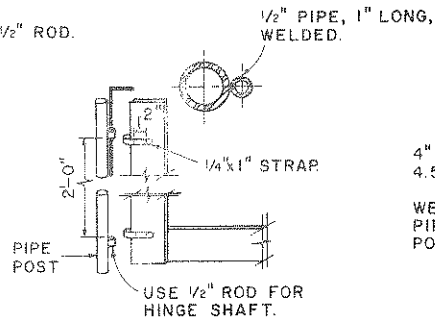
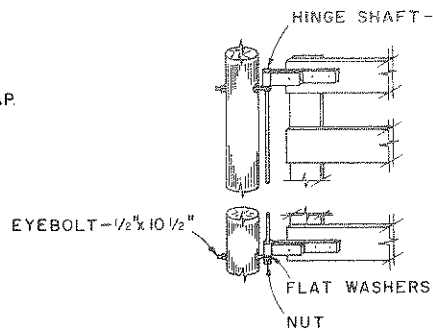

HINGES
NOT TO SCALE

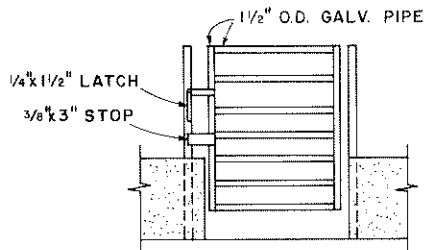
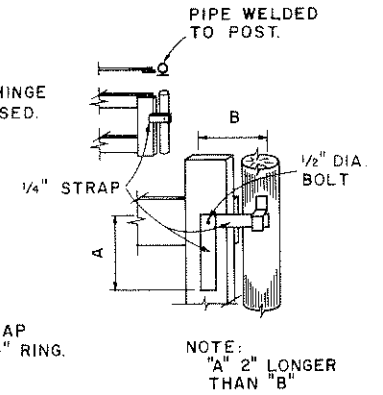
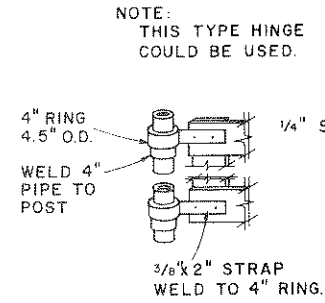

GATE DETAIL

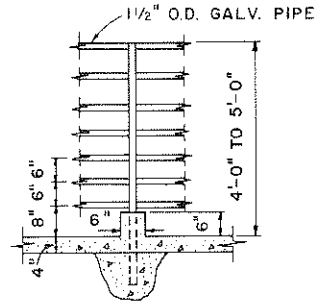

SECTION "A-A"

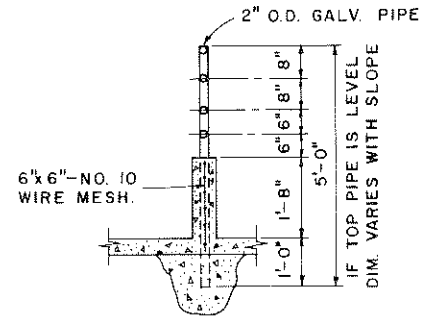

SECTION "B-B"



SCALE: 1/2" = 1'-0" UNLESS
OTHERWISE NOTED.

NOTE:
CONSULT LOCAL HEALTH AND BUILDING CODE
AUTHORITIES BEFORE STARTING CONSTRUCTION.

COOPERATIVE EXTENSION WORK IN
AGRICULTURE AND HOME ECONOMICS

AND
UNITED STATES DEPARTMENT OF AGRICULTURE COOPERATING

HOG HOUSE FOR BOARS

MISS. '75 6207 SHEET 2 OF 2