

This design is based on the use of American Plywood Association Grade-Trademarked plywood. Structural deficiencies may result with the substitution of materials. Because erection of the structure cannot be supervised no liability can be assumed by the designer or the American Plywood Association. Mention of a trade name does not constitute a guarantee or warranty of the product by the U.S. Department of Agriculture or an endorsement by the Department over other products not mentioned.

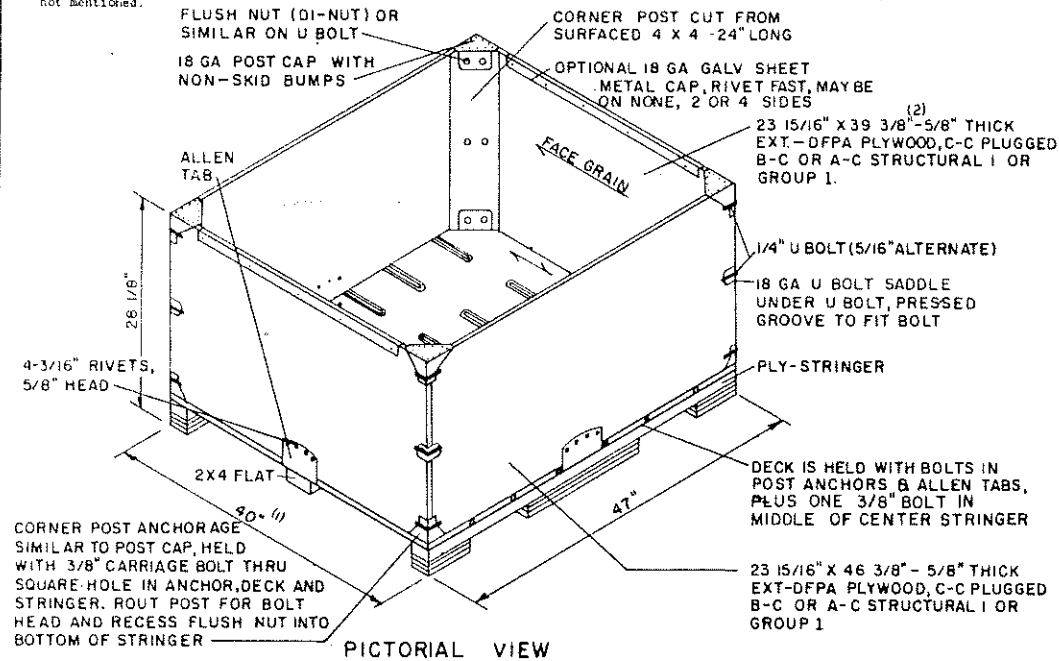

PICTORIAL VIEW

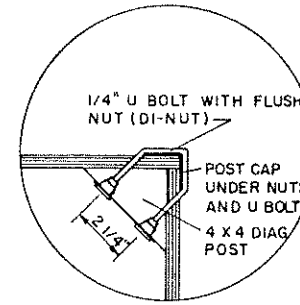

CORNER POST

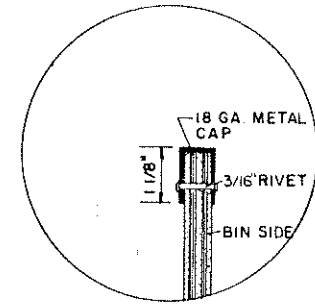

TOP EDGE CAP

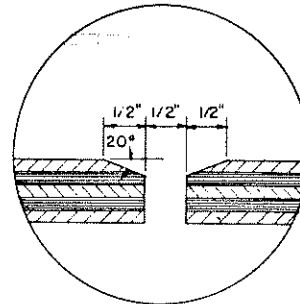

SECTION THRU SLOT *

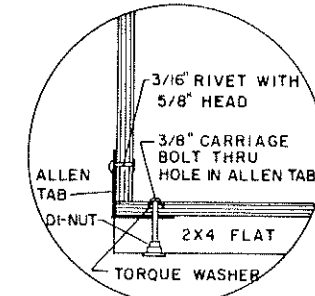

STRINGER END

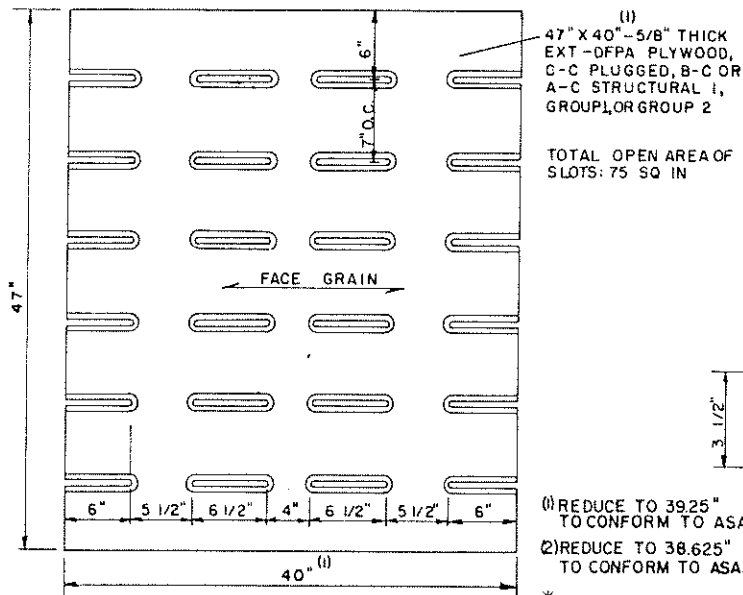

BOTTOM DETAIL *

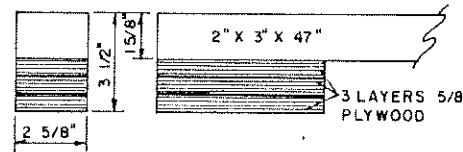

PLY - STRINGER

END BLOCKS ARE 6" X 2 5/8" X 1 7/8" THICK. CENTER BLOCK 17" X 2 5/8" X 1 7/8" THICK. BLOCKS CONSIST OF 3 LAYERS OF 5/8" EXT.-DFPA PLYWOOD FASTENED TO 2 X 3 WITH 10d RING SHANK NAILS AND BY BOLTS FASTENING BIN BOTTOM TO STRINGERS.

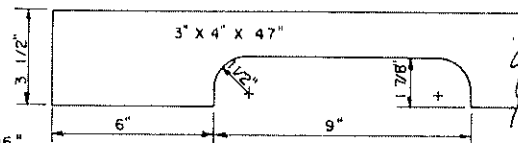

ALTERNATE STRINGER

(i) REDUCE TO 39.25" TO CONFORM TO ASAE S 337.

(2) REDUCE TO 38.625" TO CONFORM TO ASAE S 337.

* SOME BOTTOMS MANUFACTURED WITH 7 ROWS OF SLOTS. SLOTS 5/8" WIDE, PROVIDE TOTAL OPEN AREA OF 109 SQ IN. CENTER TO CENTER DISTANCE OF SLOTS AND CENTER TO EDGE SPACING IS THEN 5 7/8".

NOTE: THE SIZE OF THIS BIN IS SUCH THAT IT WILL FIT ON FLATBED TRUCKS, IN CLOSED VANS AND REFRIGERATED RAILROAD CARS. WITH ONE DIMENSION 47" IT CAN BE HANDLED IN MOST AUTOMATIC BIN HANDLING EQUIPMENT NOW BEING BUILT TO HANDLE THE STANDARD 47" X 47" BIN. THE INSIDE DEPTH OF 24" IS THE ACCEPTED STANDARD FOR MOST FRUIT AS DETERMINED BY UNIVERSITY RESEARCH.

DESIGNED TO CONFORM TO AMERICAN SOCIETY OF AGRICULTURAL ENGINEERS' RECOMMENDED INDUSTRY-WIDE STANDARDS FOR AUTOMATED HANDLING EQUIPMENT ASAE S 337.

COOPERATIVE EXTENSION WORK IN AGRICULTURE AND HOME ECONOMICS		
DEPARTMENT OF AGRICULTURAL ENGINEERING		
UNIVERSITY OF MARYLAND		
AND UNITED STATES DEPARTMENT OF AGRICULTURE COOPERATING		
PALLET BIN		
47" X 40"		
APA '71	6120	SHEET 1 OF 1