

SIDE VIEW

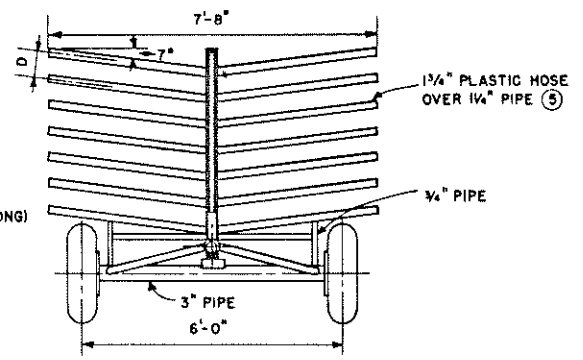

TYPICAL SECTION

	PIPE LENGTH (FT.)			PIPE DIAMETER (IN.)				
	20	30	40	2	3	4	5	6
A	14"	18"	22"					
B	6"	9"	12"					
C	7'-4"	9'-3"	11'-3"					
				5 1/4"	6 1/4"	7 1/4"	8 1/2"	9 1/2"

- KEY:
1. RACK HEIGHT IS DETERMINED BY SPRINKLER PIPE SIZE AND THE NUMBER OF TIERS REQUIRED.
  2. BASKET, FOR CARRYING SPRINKLER HEADS OR OTHER LOOSE OBJECTS, IS MADE FROM 1 1/2" ANGLE IRON AND EXPANDED METAL.
  3. BAFFLE NEEDED ONLY FOR SPRINKLER PIPE USING CENTER RISERS.
  4. POSITION HITCH SO THAT TRAILER RIDES LEVEL WHEN TOWED.
  5. CUT 1 1/4" PIPE 7'-8" LONG, BEND 14° AT CENTER, AND WELD BETWEEN CHANNELS.

SPRINKLER PIPE TRAILER		
CALIF. '68	EX. 6046	SHEET 1 OF 1

CALIF. PLAN NO. C-795-1