

PLAN

SCALE 0 4 8 12 FT.

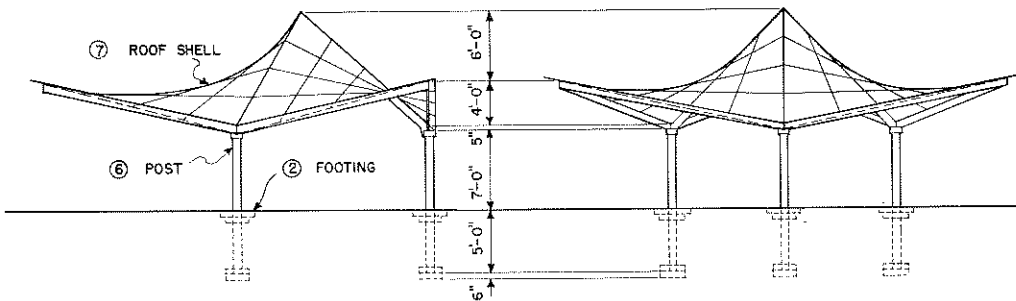

ELEVATION

END

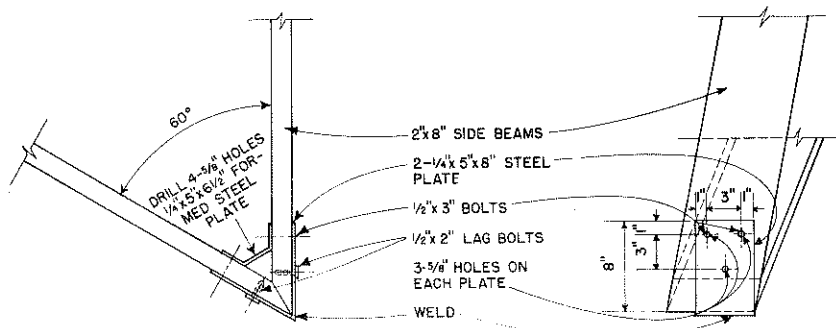

CORNER ①

SCALE: 0 1 FT.

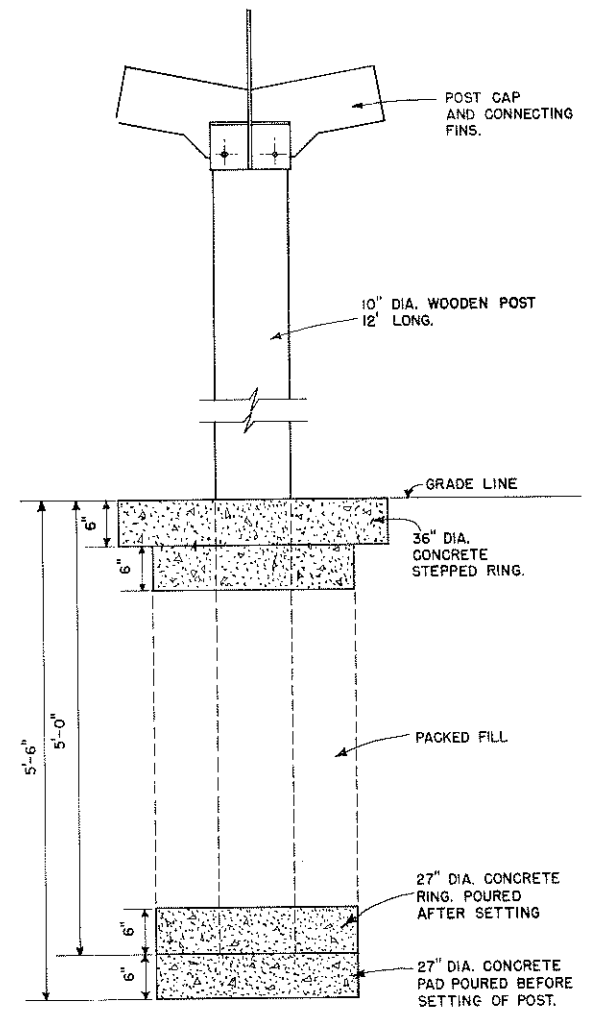

FOOTING ②  
SCALE: 0 1 FT.

COOPERATIVE EXTENSION WORK IN  
AGRICULTURE AND HOME ECONOMICS  
DEPARTMENT OF AGRICULTURAL ENGINEERING  
UNIVERSITY OF MARYLAND  
AND  
UNITED STATES DEPARTMENT OF AGRICULTURE COOPERATING

HP PICNIC SHELTER

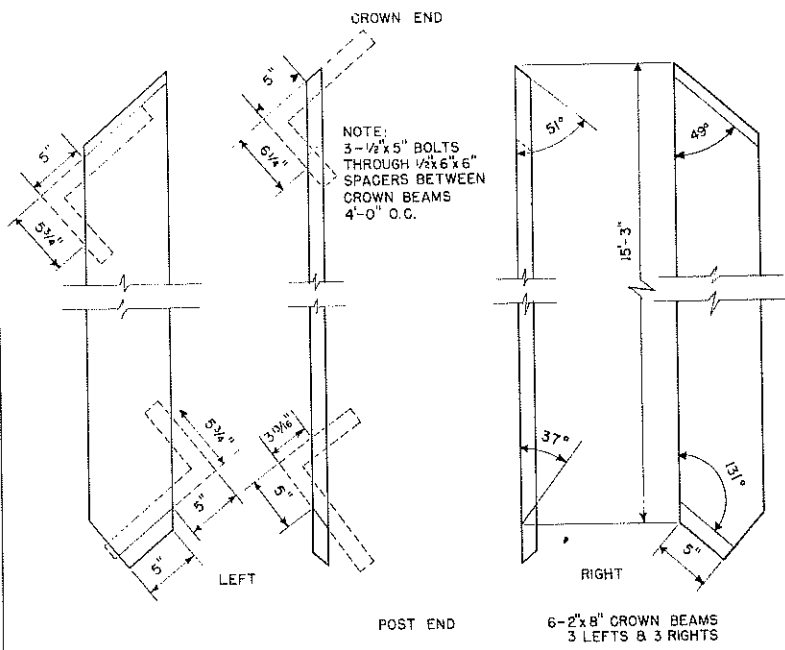

**CROWN BEAMS (3)**  
SCALE: 0 1 FT.

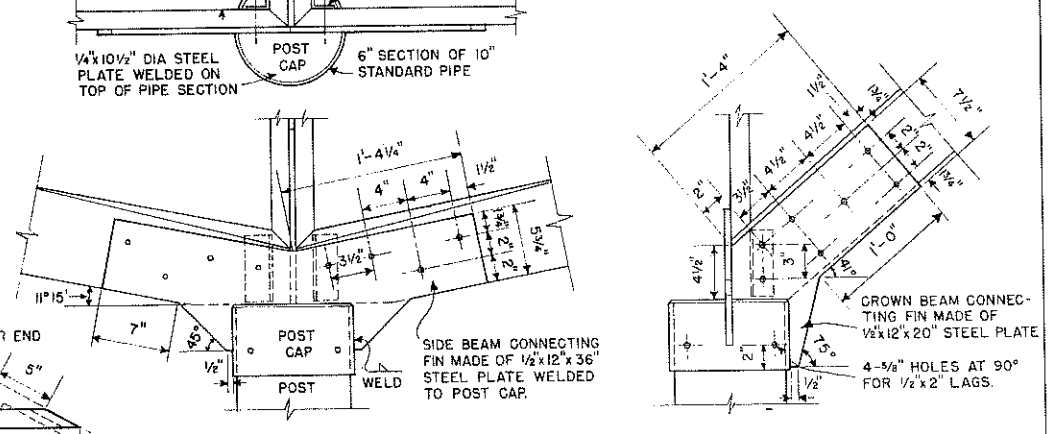
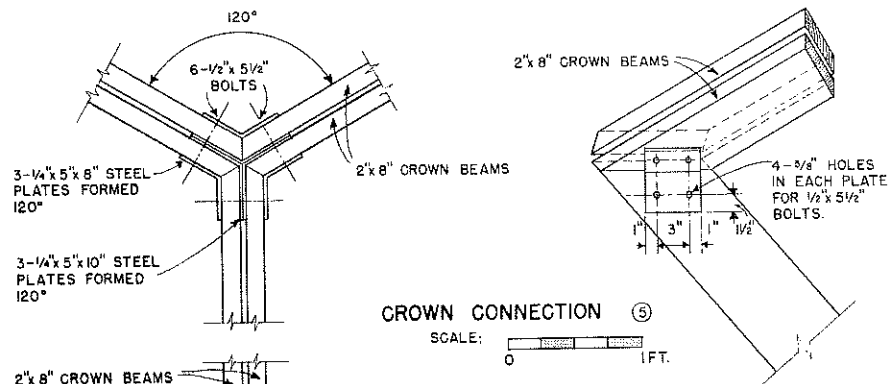

**POST CAP & CONNECTING DETAILS (6)**  
SCALE: 0 1 FT.

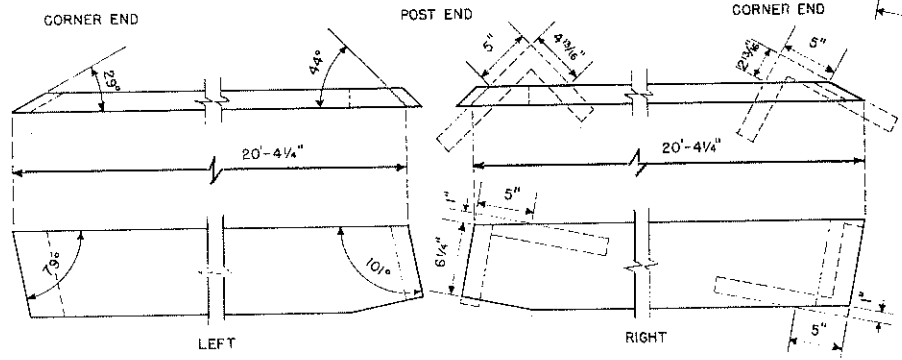

**SIDE BEAMS (4)**  
SCALE: 0 1 FT.

6-2' x 8" SIDE BEAMS  
3 LEFTS & 3 RIGHTS

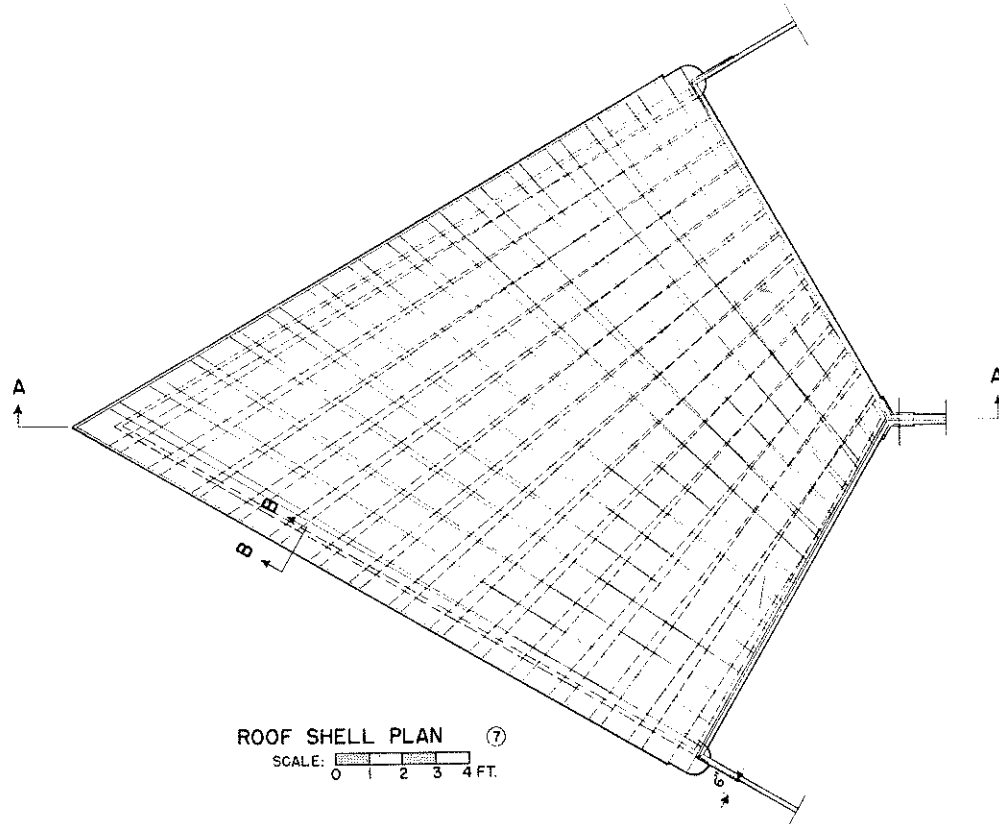

ROOF SHELL PLAN (7)  
SCALE: 0 1 2 3 4 FT.

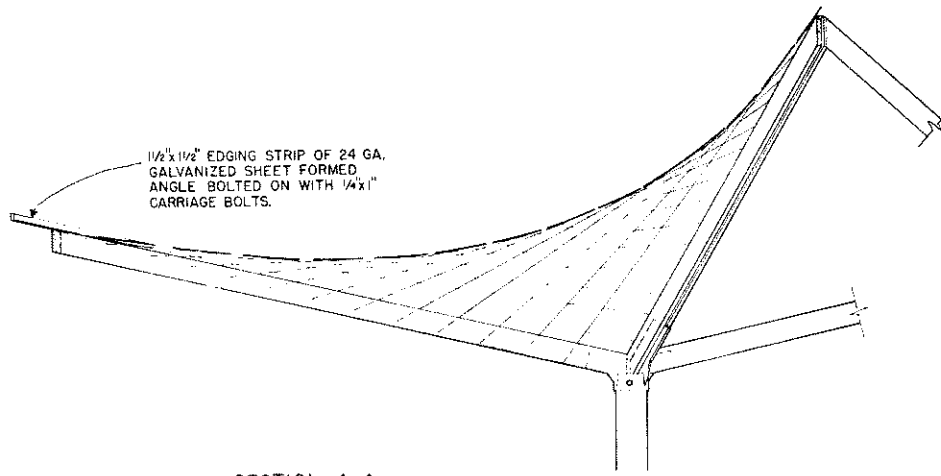

SECTION A-A  
SCALE 0 1 2 3 4 FT.

### INSTRUCTIONS

LAY OUT AN EQUILATERAL TRIANGLE, 20'-0" ON A SIDE AND DIG THREE HOLES CENTERED AT THE CORNERS.

POUR A CONCRETE FOOTING IN EACH HOLE.

PLACE TREATED POSTS IN THE CENTERS OF THE HOLES, BRACE THEM PLUMB AND POUR A CONCRETE COLLAR AROUND THE BASE OF EACH POST. BACKFILL WITH WELL-TAMPED EARTH AND POUR THE CONCRETE COLLARS AT GRADE.

PLACE THE POST CAPS AND INSTALL THE CROWN BEAMS.

ANCHOR THE POST CAPS AND INSTALL THE SIDE BEAMS WITH TEMPORARY SHORING TO PROVIDE SUPPORT UNTIL THE ROOF SHELL IS COMPLETED.

TO AID IN APPLYING THE ROOF STRIPS, INSTALL THREE 2x4" TEMPORARY RAFTERS AT QUARTER POINTS BETWEEN THE CROWN BEAM AND THE OPPOSITE SIDE BEAM.

BEVEL THE TOP EDGES OF THE BEAMS TO SUIT THE ROOF STRIPS.

TWENTY-SIX GAGE GALVANIZED STEEL STRIPS, 1"x12", PUNCHED FOR TWO 6d NAILS AND TWO 3/8" BOLTS, ARE NAILED ACROSS EACH PAIR OF CROWN BEAMS ABOUT 12" APART.

THE ROOF STRIPS ARE 1/4" TEMPERED HARDBOARD 12" WIDE. EACH SEGMENT OF THE ROOF SHELL IS FORMED OF TWO LAYERS OF FIFTEEN STRIPS. THE STRIPS EXTEND FROM THE CROWN BEAMS TO THE SIDE BEAMS, AND ARE NAILED WITH 6d NAILS SPACED 4" TO 6" APART. THE FIRST STRIP IN THE BOTTOM LAYER IS APPLIED ALONG THE SIDE BEAM IN THE OPPOSITE DIRECTION TO THE TEMPORARY RAFTERS, ALLOWING A 6" OVERHANG. FROM THE OUTER EDGE OF THE OVERHANG, MARK THE CROWN BEAM AND THE OPPOSITE SIDE BEAM INTO 15 EQUAL SPACES. THESE MARKS LOCATE THE OUTER EDGES OF THE ENDS OF THE ROOF STRIPS. THE STRIPS WILL BE SPACED APART AT THE ENDS BUT THEIR EDGES SHOULD BUTT TOGETHER ABOUT OVER THE TEMPORARY RAFTER NEAREST THE CROWN.

THE TOP LAYER OF STRIPS IS APPLIED IN A SIMILAR MANNER BUT IN THE OPPOSITE DIRECTION. AS THE STRIPS ARE LAID, WORKING FROM THE SIDE BEAM TOWARD THE CROWN BEAM, THEY ARE FASTENED TO THE BOTTOM LAYER WITH AT LEAST TWO 3/4"x1" CARRIAGE BOLTS WITH WASHERS AT EACH INTERSECTION.

TO COVER THE SPACES BETWEEN THE STRIPS OF THE BOTTOM LAYER, HEAVY FIBERGLASS FABRIC IS PLACED BETWEEN THE LAYERS IN STRIPS AT LEAST 12" WIDE.

END SPLICING OF STRIPS SHOULD BE MADE UNDER OR ABOVE A STRIP OF THE OTHER LAYER. CARE SHOULD BE TAKEN TO STAGGER THE SPLICE IN ADJACENT STRIPS.

TRIM THE EDGES OF THE FINISHED SHELL SEGMENTS, BOLT THEM TO THE STEEL STRIPS AT THE CROWN BEAMS AND APPLY THE METAL EDGING STRIPS ALONG THE OVERHANG.

ADDITIONAL FIBERGLASS STRIPS, CEMENTED WITH EMULSIFIED ASPHALT ROOF COATING, ARE APPLIED OVER THE SPACES BETWEEN THE HARDBOARD STRIPS OF THE TOP LAYER. THE ENTIRE ROOF IS COATED WITH STABILIZED ASPHALT. THE THREE RIDGES ABOVE CROWN BEAMS MAY ALSO BE WEATHER PROOFED BY THE SAME PROCESS.

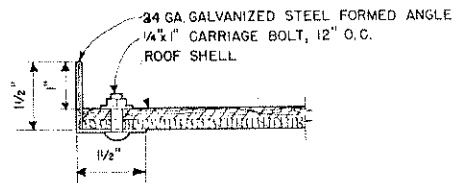

SECTION B-B

COOPERATIVE EXTENSION WORK IN  
AGRICULTURE AND HOME ECONOMICS  
DEPARTMENT OF AGRICULTURAL ENGINEERING  
UNIVERSITY OF MARYLAND  
UNITED STATES DEPARTMENT OF AGRICULTURE COOPERATION

HP PICNIC SHELTER

USDA 46 EX 5995 SHEET 3 OF 3