

ELEVATION & SECTION OF LOUVER  
SCALE: 0 1 2 3 FT.

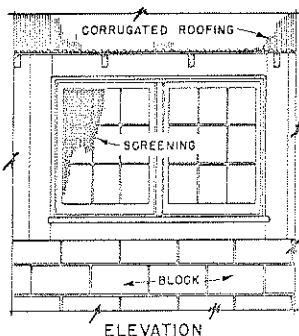

ELEVATION

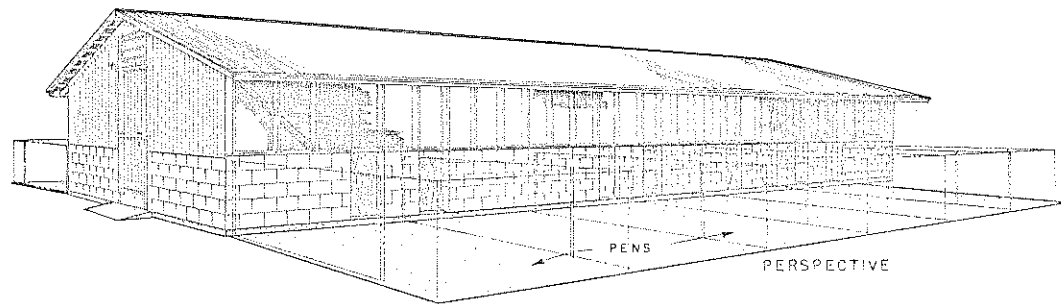
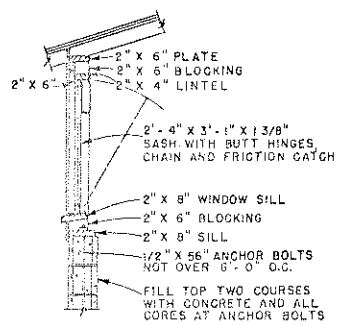

SECTION

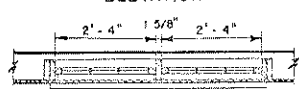

PLAN

DETAILS OF SASH  
SCALE: 0 1 2 3 FT.

WIRING LEGEND

- LIGHT OUTLET
- ⊙ BROODER LAMP OUTLET
- ⊕ DUPLEX OUTLET
- ⊖ 3 WAY SWITCH
- ⊙ OUTDOOR FLOOD LIGHTS
- S SWITCH

2" x 4" DIAG. BRACE AT ALL CORNERS NAILED TO UNDER SIDE OF RAFTER

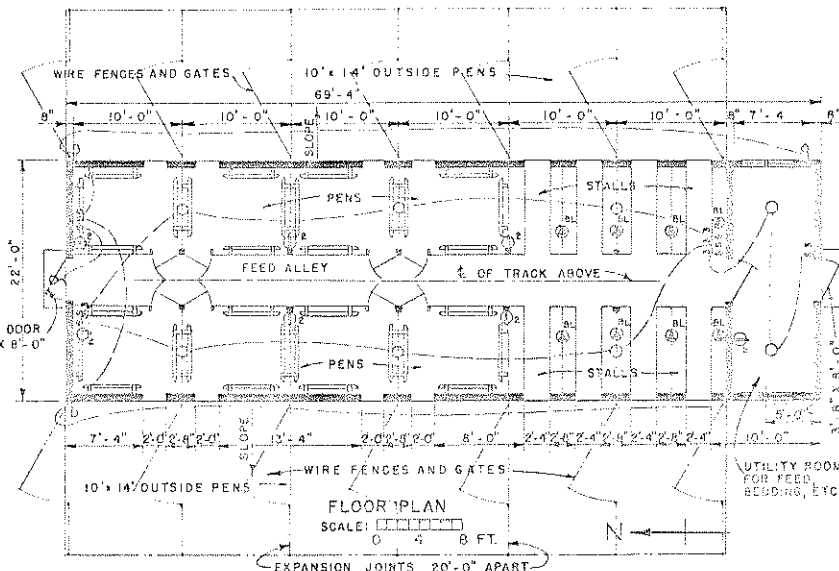

FLOOR PLAN

SCALE: 0 4 8 FT.

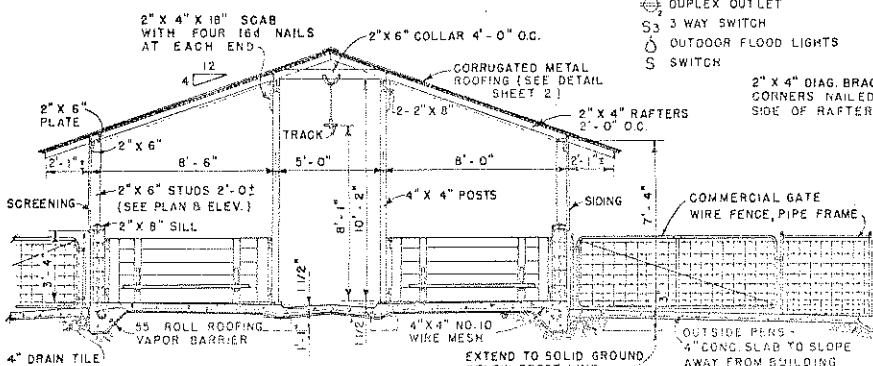

CROSS SECTION

SCALE: 0 2 4 6 FT.

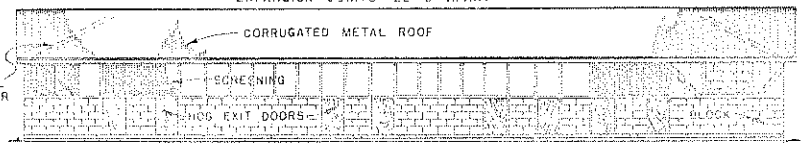

WEST ELEVATION

(EAST ELEVATION SIMILAR)

SCALE: 0 4 8 12 FT.

SINGING IS NAILED TO 1" x 6" DIAG. BRACES WITH 2-4d NAILS IN EACH BOARD. BRACES ARE NOTCHED INTO STUDS AND SILL

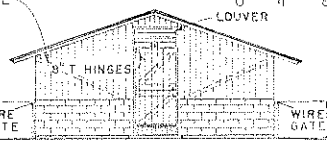

SOUTH ELEVATION

(NORTH ELEVATION SIMILAR)

SCALE: 0 4 8 12 FT.

NOTE

BR/PROOF FEED ROOM BY COVERING LOWER 18" OF DOORS WITH 25 GA. GALV. SHEET STEEL.

COOPERATIVE EXTENSION WORK IN AGRICULTURE AND HOME ECONOMICS  
DEPARTMENT OF AGRICULTURAL ENGINEERING  
UNIVERSITY OF MARYLAND  
AND  
UNITED STATES DEPARTMENT OF AGRICULTURE COOPERATING

CENTRAL FARROWING HOUSE

USDA '56 EX. 5822 SHEET 1 OF 2

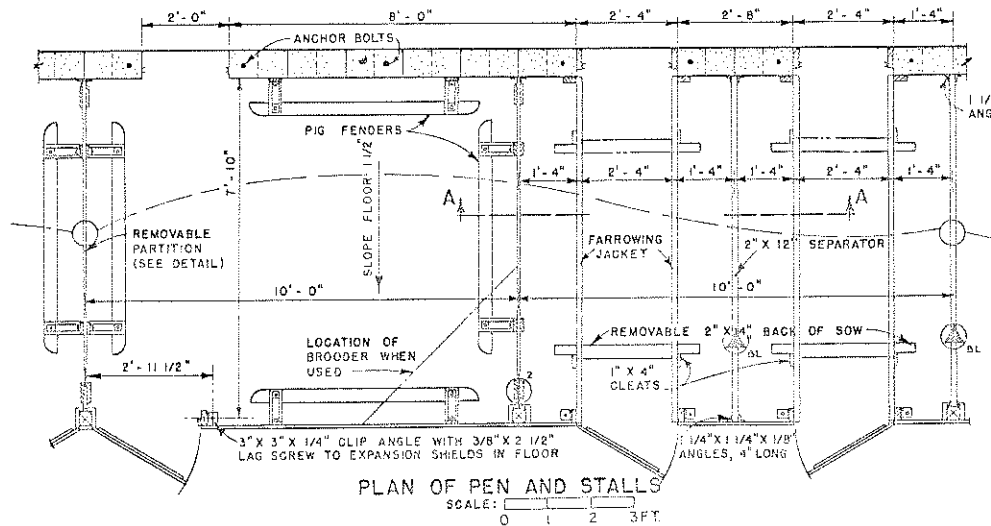

PLAN OF PEN AND STALLS  
SCALE: 0 1 2 3 FT.

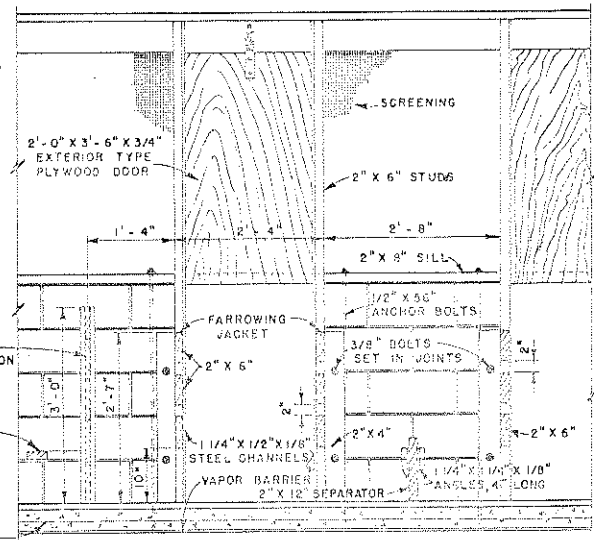

SECTION THRU FARROWING STALLS AT A-A  
SCALE: 0 1 2 FT.

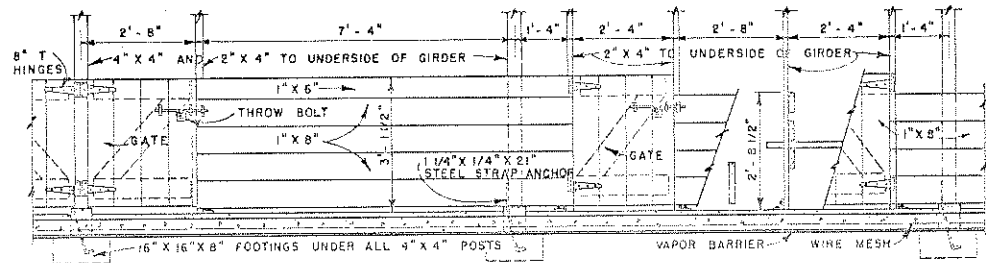

ELEVATION OF PEN AND STALL FRONTS  
(GUT AWAY TO SHOW CONSTRUCTION)  
SCALE: 0 1 2 3 FT.

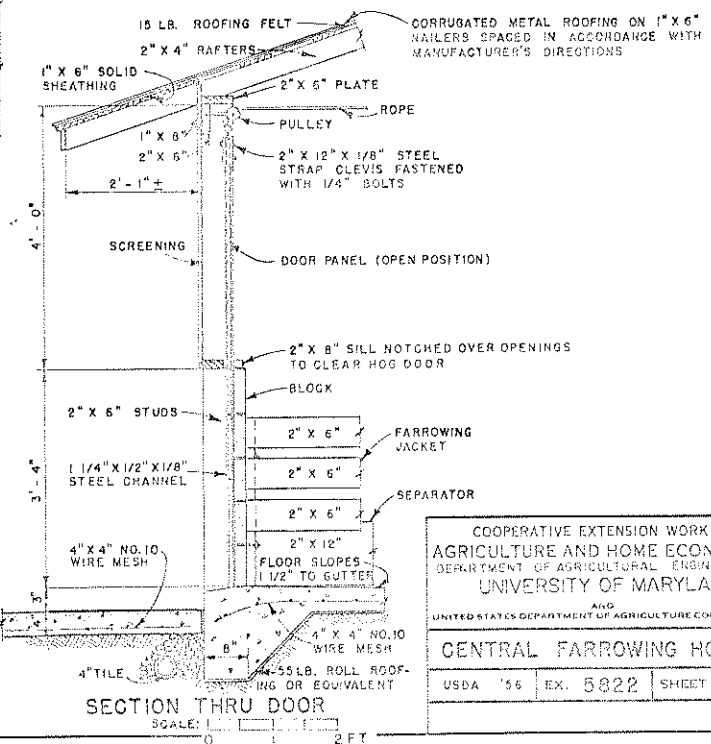

SECTION THRU DOOR  
SCALE: 0 1 2 FT.

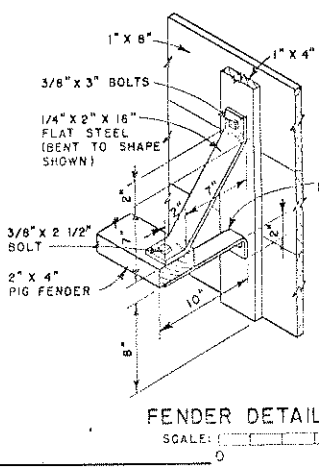

FENDER DETAIL  
SCALE: 0 1 FT.

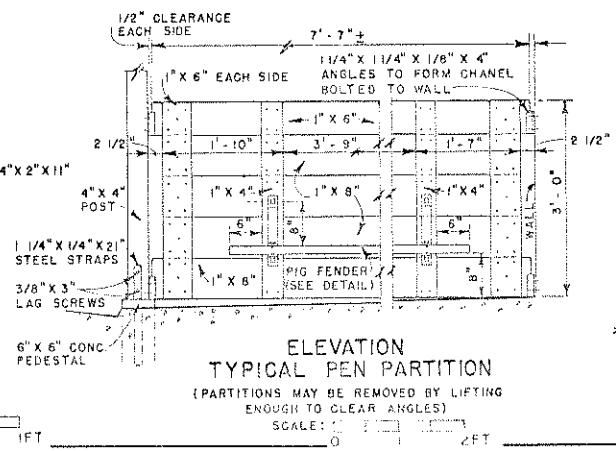

ELEVATION TYPICAL PEN PARTITION  
(PARTITIONS MAY BE REMOVED BY LIFTING ENOUGH TO CLEAR ANGLES)  
SCALE: 0 1 2 FT.

COOPERATIVE EXTENSION WORK IN  
AGRICULTURE AND HOME ECONOMICS  
DEPARTMENT OF AGRICULTURAL ENGINEERING  
UNIVERSITY OF MARYLAND  
UNITED STATES DEPARTMENT OF AGRICULTURE COOPERATING

CENTRAL FARROWING HOUSE

USDA '56	EX. 5822	SHEET 2 OF 2
----------	----------	--------------