

END ELEVATION

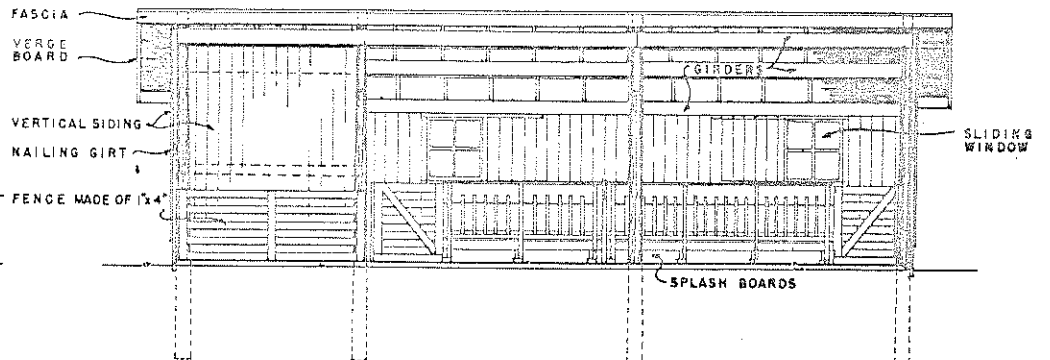

FRONT ELEVATION

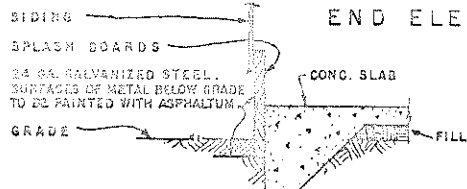

RATPROOFING OF FEED ROOM

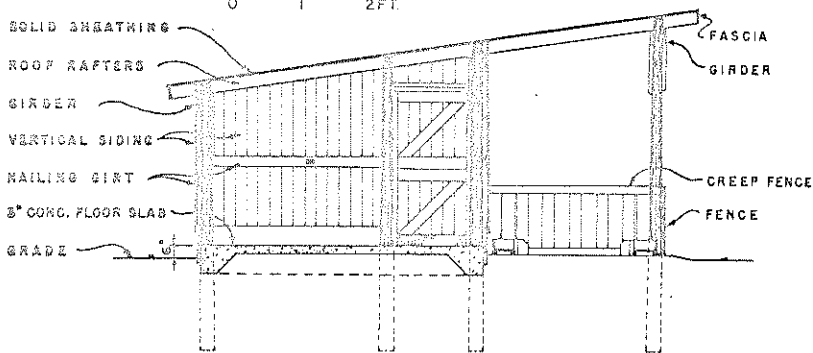

SECTION A-A

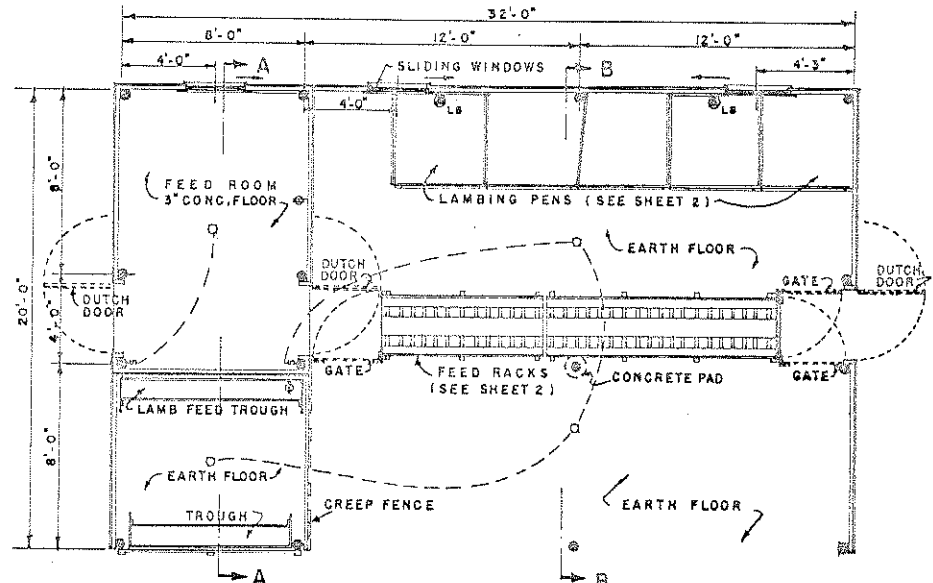

FLOOR PLAN

LIST OF MATERIALS

THIS LIST OF MATERIALS IS PREPARED FOR ESTIMATING PURPOSES; IF USED FOR THE PURCHASE OF MATERIALS, THE QUANTITIES SHOULD BE VERIFIED BY THE BUILDER.

ITEM	SIZE	PIECES
POLES (PRESSURE TREATED), 1 1/2" TOP DIA.	15' LONG	6
	13' LONG	7
SPLASH BOARDS (PRESSURE TREAT.)	2" x 10" x 14'-0"	1
	2" x 10" x 12'-0"	3
	2" x 10" x 10'-0"	10
	2" x 10" x 8'-0"	2
	2" x 8" x 12'-0"	2
	2" x 8" x 10'-0"	9
	2" x 8" x 20'-0"	4
	2" x 10" x 20'-0"	2
	2" x 8" x 12'-0"	4
	2" x 10" x 12'-0"	2
	2" x 8" x 14'-0"	17
	2" x 6" x 10'-0"	17

ITEM	SIZE	PIECES
VERGE BOARDS	2" x 6" x 12'-0"	4
FASCIA	1" x 10" x 10'-0"	1
	1" x 6" x 12'-0"	6
HEAD (DOORS) & SCABS	2" x 4" x 12'-0"	4
JAMB (DOORS)	2" x 4" x 8'-0"	4
SIDING & DOORS	85R BM 1x6" T & G	9
SILL FOR WINDOWS	2" x 4" x 10'-0"	1
FILLER FOR SLIDING WINDOWS	2" x 2" x 10'-0"	1
CASING	1" x 4" x 12'-0"	5
ROOF SHEATHING	9 3/8 BM 1x6" T & G	1
ROOFING	9 SQUARES	9
WINDOWS	3/4" LT. SLIDING BARN SASH	9
HARDWARE	6 PR. 5" STRAP HINGES, 8 BARREL BOLTS, GUTTERS, DOWNSPOUTS, NAILS & PAINT	
CONCRETE	(1-2 1/2 x 3/2) MIX x 2 1/2 CU. YD. OR 15 SACKS CEMENT, 1 1/4 CU. YD. SAND AND 1 1/4 CU. YD. GRAVEL	
RATPROOFING	24 GA. GALV. STEEL 26" WIDTH - 42 FT.	

WIRING SYMBOLS

- CEILING OUTLET
- ⊗ DUPLEX OUTLET
- S SINGLE SWITCH
- ⊗ LB LAMB BROODER

NOTE: THIS BUILDING IS DESIGNED FOR USE IN AREAS WHERE THE SNOW LOAD DOES NOT EXCEED 20 LBS. PER SQUARE FOOT AND WINDS ARE NOT ABOVE 76 MILES PER HOUR.  
 LIST OF MATERIALS IS FOR BUILDING ONLY, DOES NOT INCLUDE GATES, TROUGH, RACKS, FENCES AND PENS.

COOPERATIVE EXTENSION WORK IN AGRICULTURE AND HOME ECONOMICS  
 DEPARTMENT OF AGRICULTURAL ENGINEERING  
 UNIVERSITY OF MARYLAND  
 AND  
 UNITED STATES DEPARTMENT OF AGRICULTURE COOPERATING

**SHEEP SHED**  
 POLE CONSTRUCTION

USDA '35 EX. 5812 SHEET 1 OF 2

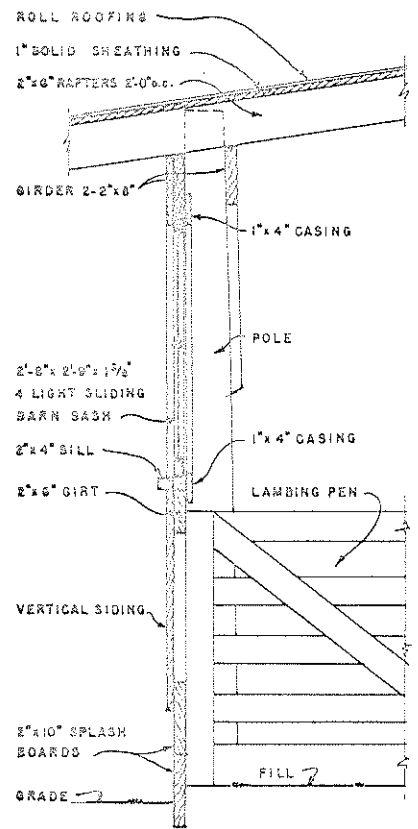

SECTION THRU REAR WALL

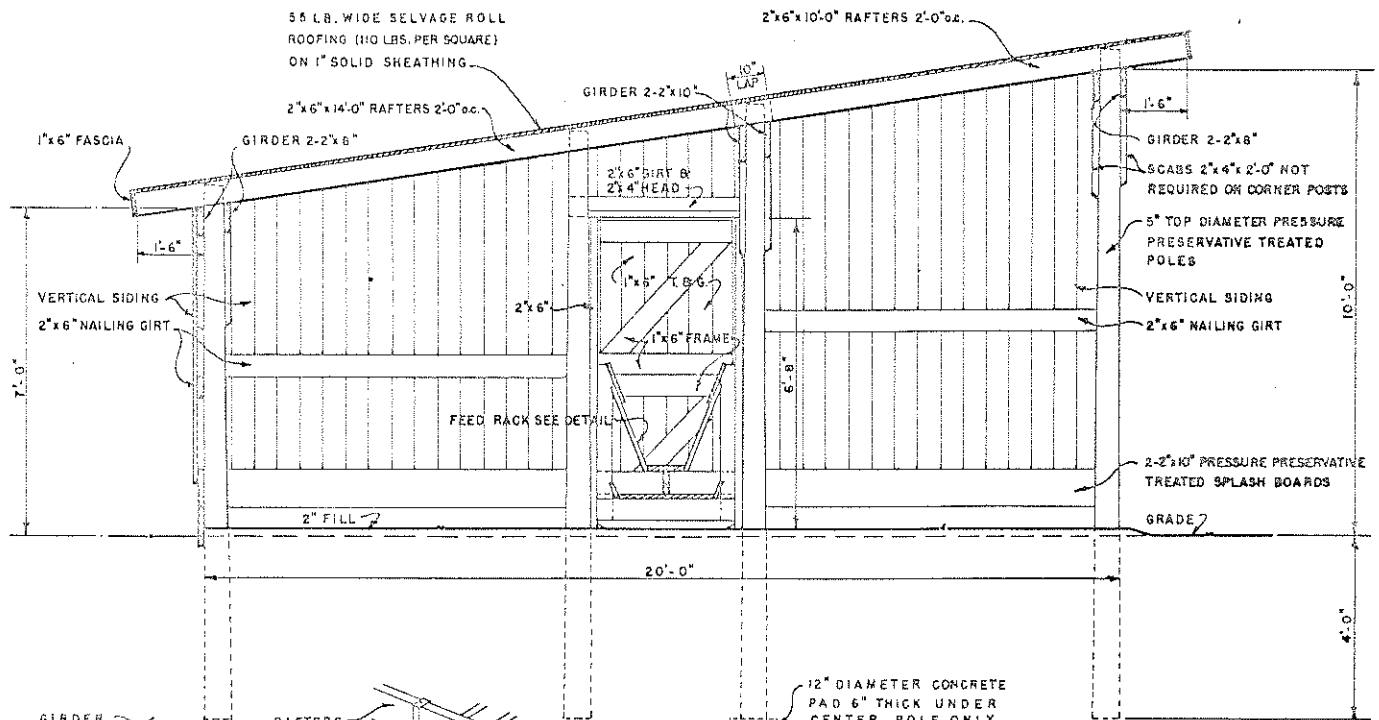
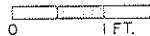

SECTION B-B

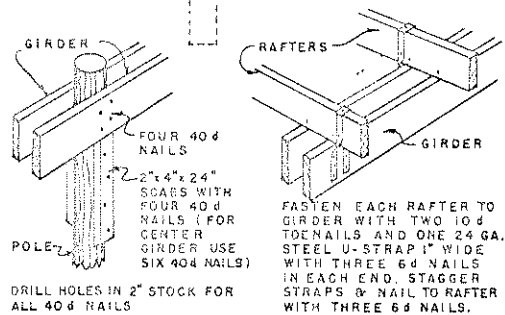
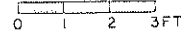

NAILING DETAIL  
NO SCALE

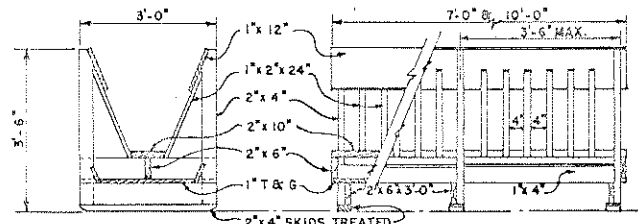

SECTION

ELEVATION

FEED RACKS

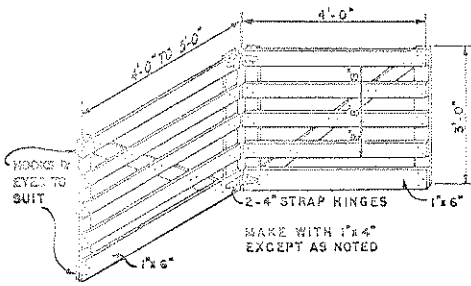
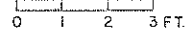

HINGED PANELS FOR TEMPORARY LAMBING PENS

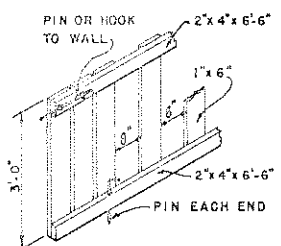
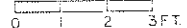

CREEP FENCE

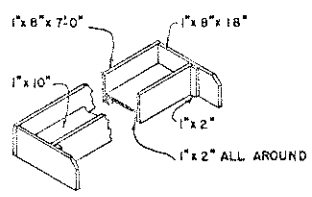

LAMB FEED TROUGH

COOPERATIVE EXTENSION WORK IN AGRICULTURE AND HOME ECONOMICS  
DEPARTMENT OF AGRICULTURAL ENGINEERING  
UNIVERSITY OF MARYLAND  
AND  
UNITED STATES DEPARTMENT OF AGRICULTURE COOPERATING

**SHEEP SHED**  
POLE CONSTRUCTION

USDA	'55 EX. 5812	SHEET 2 OF 2
------	--------------	--------------