

STANCHION END

This view shows a simply designed stanchion. The head holding rails are held in place with pins in the cross rail and also by a rope fastened as shown.

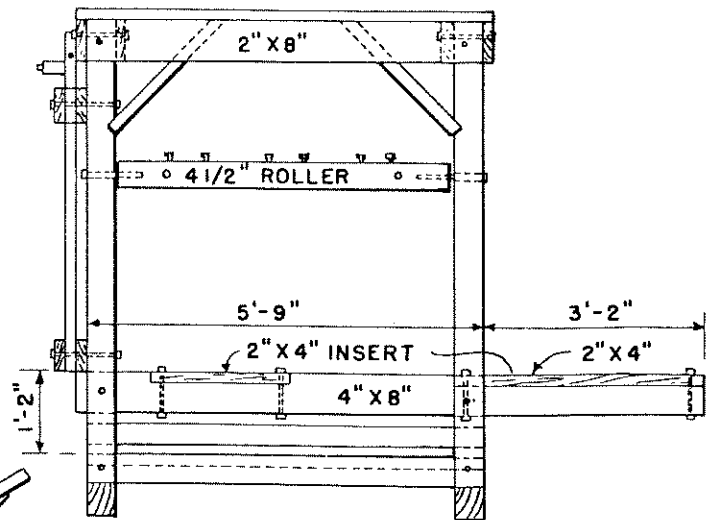

SIDE VIEW

The canvas sling winds up on the side rollers. The 2" x 4" hardwood inserts are bolted for easy replacement after damage caused from trimming hoofs.

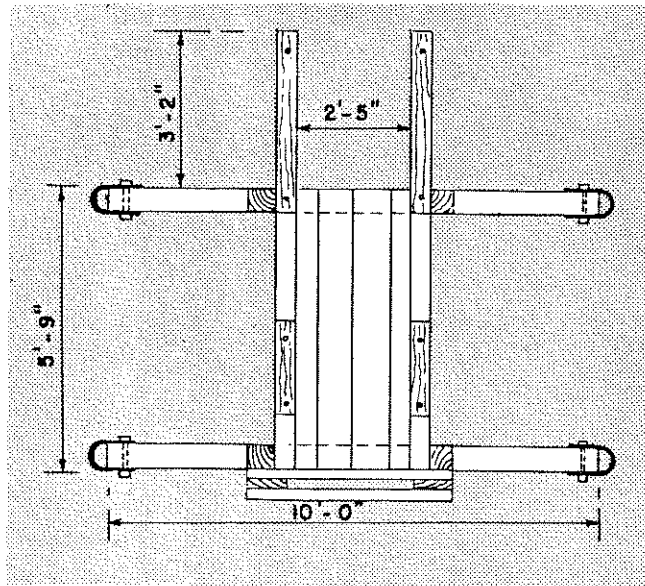

PLAN VIEW

A 2" x 8" plank can be placed on edge across the floor under the stanchion to keep animal's front feet from slipping off front of platform.

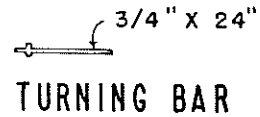

TURNING BAR

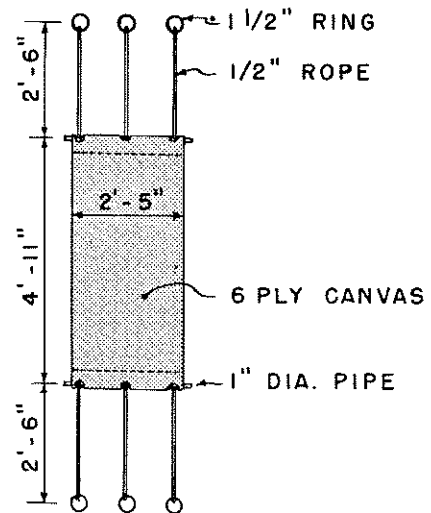

CANVAS SLING

Four bars like the one shown above are usually required for turning the rollers on which the canvas sling is attached. A lug is welded 3" from end of bar.

*All wood should be pressure treated with preservative.*