

SOUTH ELEVATION
SCALE $\frac{1}{4}'' = 1'-0''$

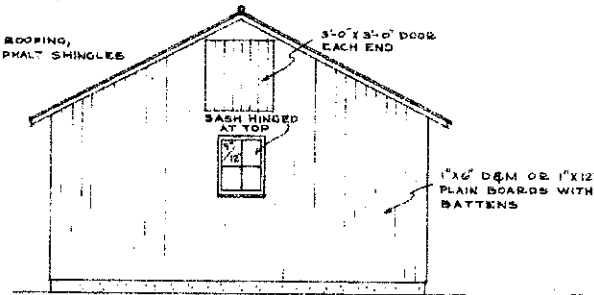

EAST ELEVATION (WEST SIMILAR)
SCALE $\frac{1}{4}'' = 1'-0''$

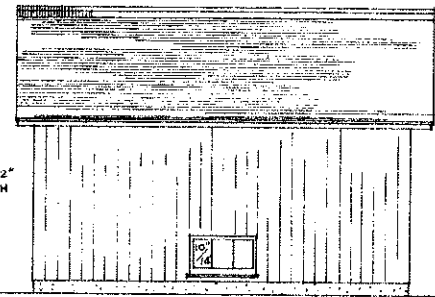

NORTH ELEVATION
SCALE $\frac{1}{4}'' = 1'-0''$

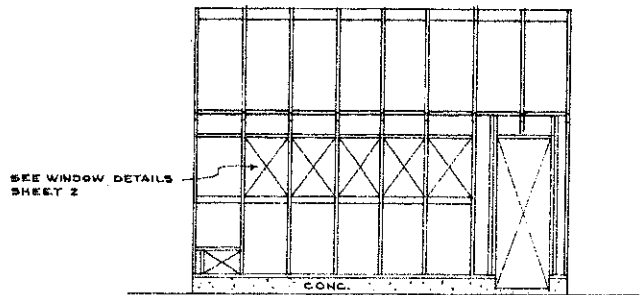

SEE WINDOW DETAILS
SHEET 2

SOUTH

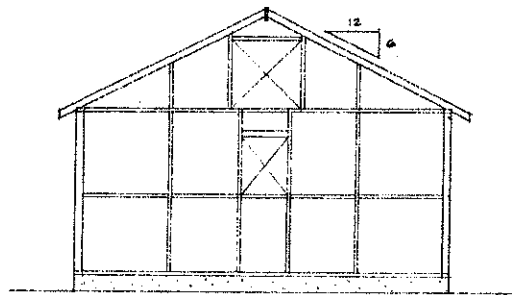

EAST & WEST

FRAMING ELEVATIONS
SCALE $\frac{1}{4}'' = 1'-0''$

BILL OF MATERIALS CONT'D

NO. PCS.	SIZE	DESCRIPTION
16	3 3/4 SQ. FEET 1/2" X 12"	ROOFING ANCHOR BOLTS
	2"	RIDGE ROLL (GALV.)
	286 SQ. FT. (1 1/2" MIN)	POULTRY NETTING
3 PRS	6" T	HINGES
8 PRS	1 1/2" BUTT	HINGES
10		SPRING BOLTS
13 LIN. FT.		WIRE COIL CHAIN
1		(RIM) LOCKSET
3# 25# OF 20D & 10D		COM. NAILS
10# 25# OF 8D & 6D		COM. NAILS
2 GAL.	2 COATS	LEAD & OIL PAINT
3 CU. YDS		FOUNDATION & FLOOR CONCRETE
230	4" X 12" X 12'-0"	UNDER FLOOR TILE
4.2 CU. YDS		GRAVEL OR CINDER FILL

BILL OF MATERIALS

NO. PCS.	SIZE	DESCRIPTION
4	2" X 6" X 16'-0"	SILLS
3	2" X 4" X 8'-0"	JACK STUDDING
18	2" X 4" X 16'-0"	STUDDING
4	2" X 4" X 16'-0"	HEADERS
4	2" X 4" X 8'-0"	GIRTS
4	2" X 4" X 16'-0"	PLATES
3	2" X 6" X 16'-0"	BRACING
18	2" X 4" X 10'-0"	RAFTERS
1	1" X 6" X 16'-0"	RIDGE
	1" X 8" SHIPLAP	ROOF SHEATHING
1	2" X 4" X 10'-0"	WINDOW SILLS
1	2" X 4" X 8'-0"	WINDOW SILLS
	1" X 6" DEM	SIDING
15	1" X 4" X 10'-0"	FRIEZE & FASCIA
3	1" X 6" X 14'-0"	DOORS
4	1" X 6" X 12'-0"	DOORS
2	1" X 8" X 12'-0"	DOOR BATTENS
1	1" X 6" X 12'-0"	DOOR BATTENS
16	2" X 2" X 16'-0"	STRAW FRAMES
5	2" X 4" X 8'-0"	ROOSTS
3	2" X 2" X 16'-0"	ROOSTS
12	1" X 6" X 16'-0"	ROOSTS
2	1" X 4" X 16'-0"	ROOSTS
1	1" X 4" X 12'-0"	ROOST
2	1" X 6" X 12'-0"	NESTS
1	1" X 4" X 12'-0"	NESTS
2 OF EACH	1" X 4" X 8' 4 1/2'-0"	NESTS
1	1" X 4" X 12'-0"	WINDOW BLOCKS
7 (4L)	8" X 12" X 1 1/8'-0"	(GLAZED) DRAIN SASH
4 (3L)	10" X 14" X 1 1/8'	CELLAR (GLAZED)
	444 SQ. FT.	LINING-INSULATION BOARD
	230 SQ. FT.	WATERPROOF BLDG. PAPER

COOPERATIVE EXTENSION WORK IN
AGRICULTURE AND HOME ECONOMICS
STATE OF NORTH DAKOTA
NORTH DAKOTA AGRICULTURAL COLLEGE
AND
U. S. DEPT. OF AGRICULTURE COOPERATING
EXT. AGR'L. ENGINEER - FARGO, N. DAK.

STRAW LOFT POULTRY HOUSE
MIDWEST 12711-734 24 5204 SHEET 1 OF 2

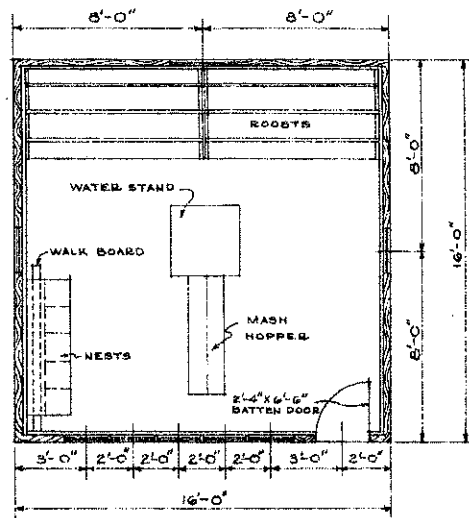

FLOOR PLAN
SCALE $\frac{1}{4}'' = 1'-0''$

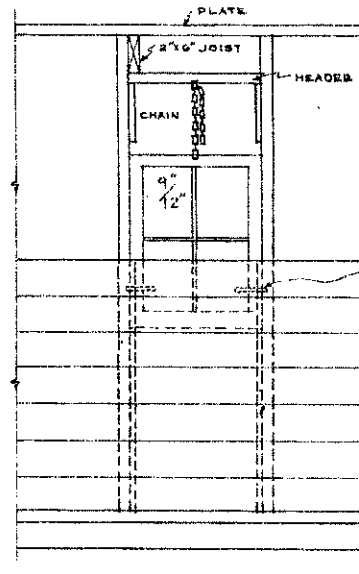

INTERIOR VIEW

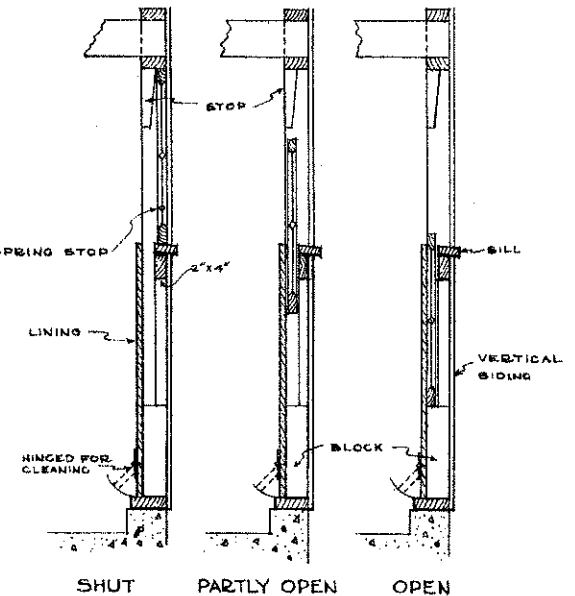

WINDOW DETAILS
SCALE $\frac{3}{4}'' = 1'-0''$

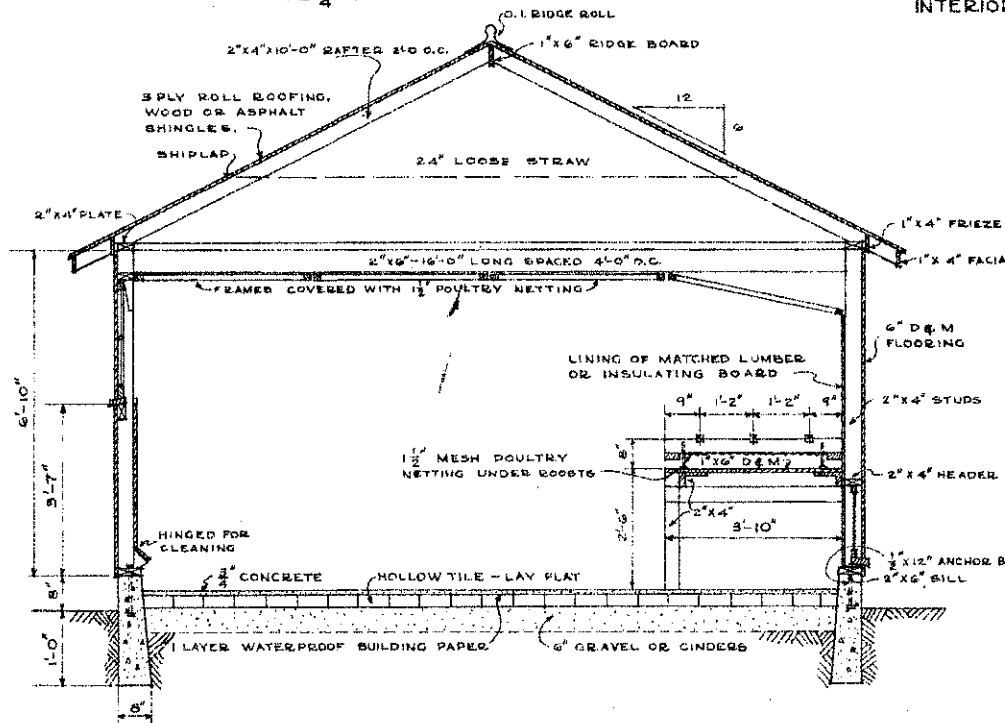

SECTION
SCALE $\frac{1}{2}'' = 1'-0''$

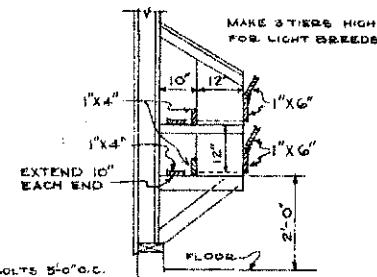

DETAIL OF NESTS
SCALE $\frac{1}{2}'' = 1'-0''$

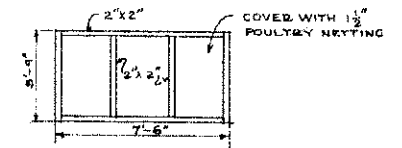

PLAN OF STRAW FRAMES
(8 REQUIRED)
SCALE $\frac{1}{4}'' = 1'-0''$

COOPERATIVE EXTENSION WORK IN
AGRICULTURE AND HOME ECONOMICS
STATE OF NORTH DAKOTA
NORTH DAKOTA AGRICULTURAL COLLEGE
AND
U. S. DEPT. OF AGRICULTURE COOPERATING
EXT. AGR'L ENGINEER - FARGO, N. DAK.
STRAW LOFT POULTRY HOUSE
MIDWEST 7-77-1-33; EX 5295 SHEET 2 OF 2